

# Product Catalogue - Motors

## Hydraulic Radial Piston Motors

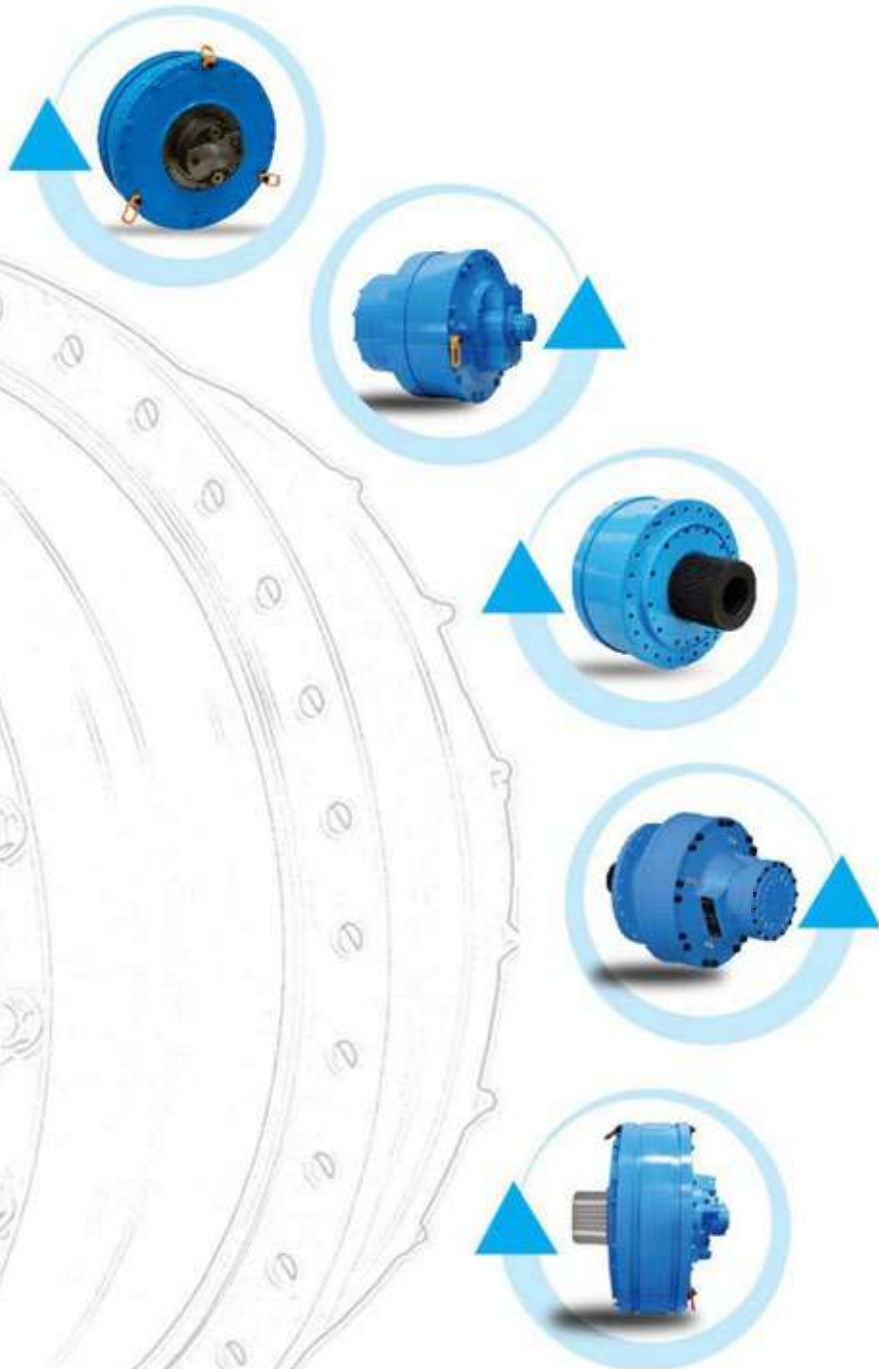

# Reliable Gearless Hydraulic Drives

For High Torque Applications



**HEAVY DUTY RADIAL PISTON MOTORS AND COMPLETE DRIVE SYSTEMS**





### HD & VHD SERIES

**HD** – ‘Heavy Duty’ Series & **VHD** – ‘Very Heavy Duty’ Series motors, are designed for High Torque – Low Speed applications where maximum power is of utmost priority.



### MD SERIES

**MD** – ‘Medium Duty’ Series motors are designed high-power ~ high-speed applications, such as Conveyors, Ball Mill & Bowl Mill Drives.



### LD SERIES

**LD** – ‘Light Duty’ Series motors are developed for high-speed applications and perform with high efficiency in tough conditions.



### 820 SERIES

**820** – (Body Diameter) motors provide high torque for high-speed applications and incorporate the “high-flow” distribution system. These motors are extensively used for Wagon tippler and high inclination conveyors where high brake torque is required.



### CR SERIES

**CR** – ‘Case Rotating Series’ motors are designed for use in Marine, Steel and Mining industries for winches, cranes and haulage equipment, where continuous duty cycle with high efficiency on varying load conditions is demanded.

# HD & VHD SERIES



**SCHRODER HD Series** hydraulic motors provide high torque characteristics for low speed applications and incorporate a “high-flow” distribution system. On special request, the motors can also be custom-made to suit high-speed requirements. The HD Series motors are torque arm mounted to eliminate installation misalignments and they are the ideal choice for applications such as Bucket Wheel Drive, Apron Feeder Drive and Kiln Drive etc. The motors operate with low noise and high efficiency with power outputs as high as 1000 KW. The Schroder HD Series motors ensure trouble free operation even in extreme environmental conditions.

## OPTIONS

- CUSTOMIZED / DOUBLE SHAFT
- INTEGRAL MULTI-PLATE DISC BRAKE
- HIGH SPEED VERSIONS
- CORROSION RESISTANT MATERIAL
- VARIOUS SIZED THROUGH-HOLE SHAFTS
- CUSTOM FINISH
- DEEP WATER SUBMERSIBLE
- NON MAGNETIC MATERIAL
- DUAL DISPLACEMENT
- SHAFT OR FLANGE MOUNTING

## FEATURES

- LONG LIFE
- HIGH MECHANICAL EFFICIENCY
- CONSTANT TORQUE OUTPUT
- SMOOTH LOW SPEED PERFORMANCE <1RPM
- RESISTANCE TO THERMAL SHOCK
- DOUBLE SHAFT SEALING
- SHRINK DISC COUPLING
- SHOCK RESISTANCE
- LOW NOISE



MOTOR FRAME SIZE	SPECIFICATIONS					
	DISP.(*) PER REV	TORQUE (THEORETICAL)	TORQUE MAX	SPEED RATED	SPEED MAX**	PRESSURE RATED
METRIC	cm <sup>3</sup> /Rev	Nm/Bar	Nm	RPM	RPM	Bar
HMA 20	20380	324	106920	45	70	350
HMA 25	25320	402	132660	40	60	350
HMA 30	30580	486	160380	35	50	350
HMA 36	35460	563	185790	32	42	350
HMA 50	50168	798	263340	26	38	350
HMA 70	70010	1004	331320	20	28	350
HMA 100	101360	1640	541200	12	18	350

\*\*High speed version upon request

\* Any other displacement upon request



# HD SERIES

DIMENSIONS:

## MOTORS WITH SHRINK DISC COUPLINGS

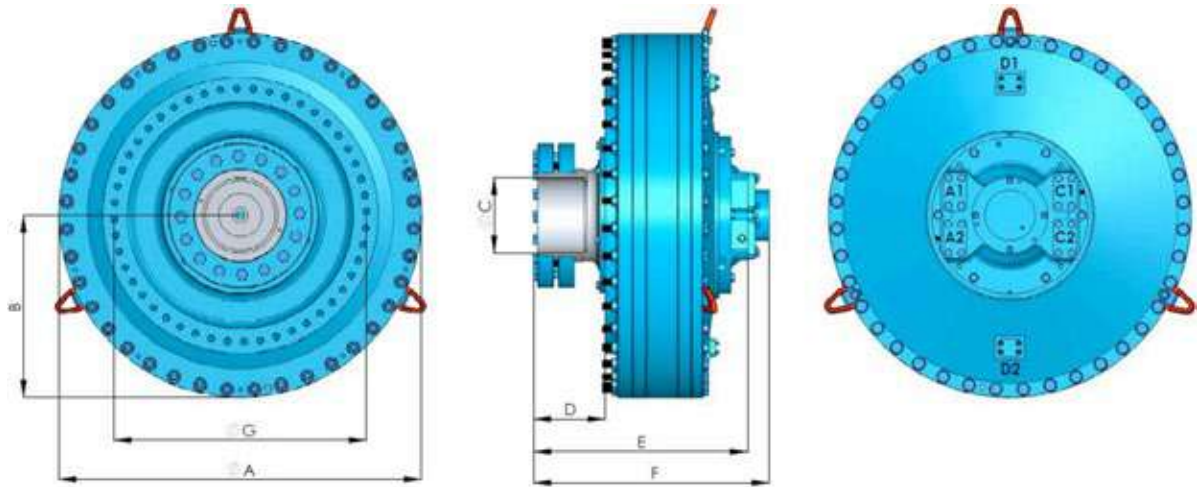

Motor	ØA (mm)	B (mm)	ØC (mm)	D (mm)	E (mm)	F (mm)	ØG (mm) Mounting Dimensions for Torque Arm or Bracket	Weight Kg	Main Conn A1, A2, C1, C2	Drain Conn D1, D2
HMA 20	1100	550	180	190	700	832	M24X 48Nos THRU HOLES AT PCD 870±0.1	2200	SAE 2"	1-1/4"SAE
HMA 25	1100	550	200	190	700	832		2350	SAE 2"	1-1/4"SAE
HMA 30	1100	550	260	243	721	853		2300	SAE 2"	1-1/4"SAE
HMA 36	1100	550	260	243	721	853		2250	SAE 2"	1-1/4"SAE
HMA 50	1250	625	260	243	760	890		2550	SAE 2"	1-1/4"SAE

\* Technical dimensions are subject to change without prior notice

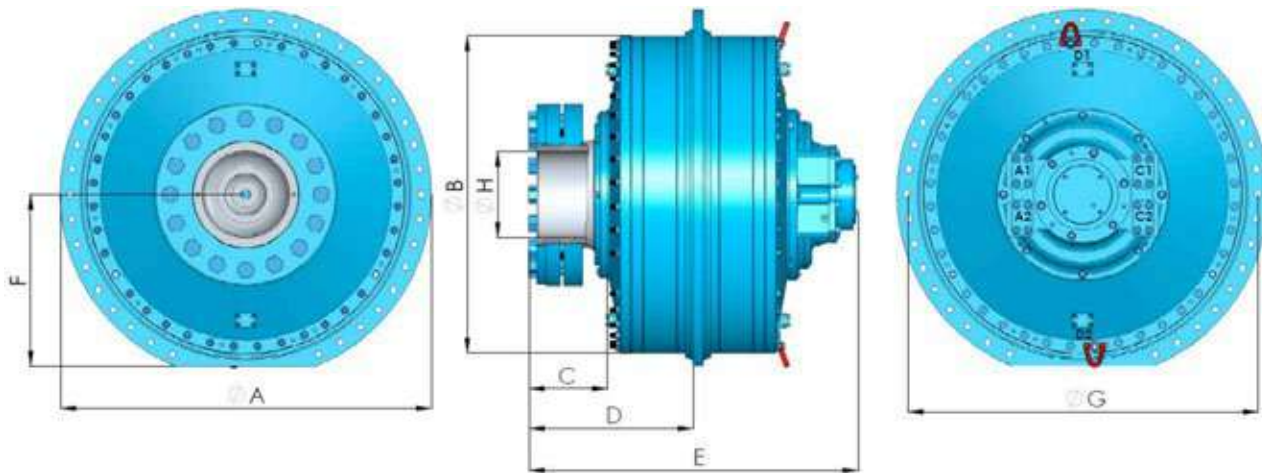

Motor	ØA (mm)	ØB (mm)	C (mm)	D (mm)	E (mm)	F (mm)	ØG (mm) Mounting Dimensions for Torque Arm	H (mm)	Weight Kg	Main conn A1, A2, C1, C2	Drain conn D1, D2
HMA 100-70	1460	1250	291	660	1295	675	Ø26X43Nos MOUNTING HOLES AT PCD 1380±0.1	340	4500	SAE 2"	1-1/4"SAE
HMA 100	1460	1250	291	660	1295	675		340	4500	SAE 2"	1-1/4"SAE

\* Technical dimensions are subject to change without prior notice

# HD SERIES

## DIMENSIONS: HOLLOW SHAFT MOTORS WITH FEMALE SPLINES

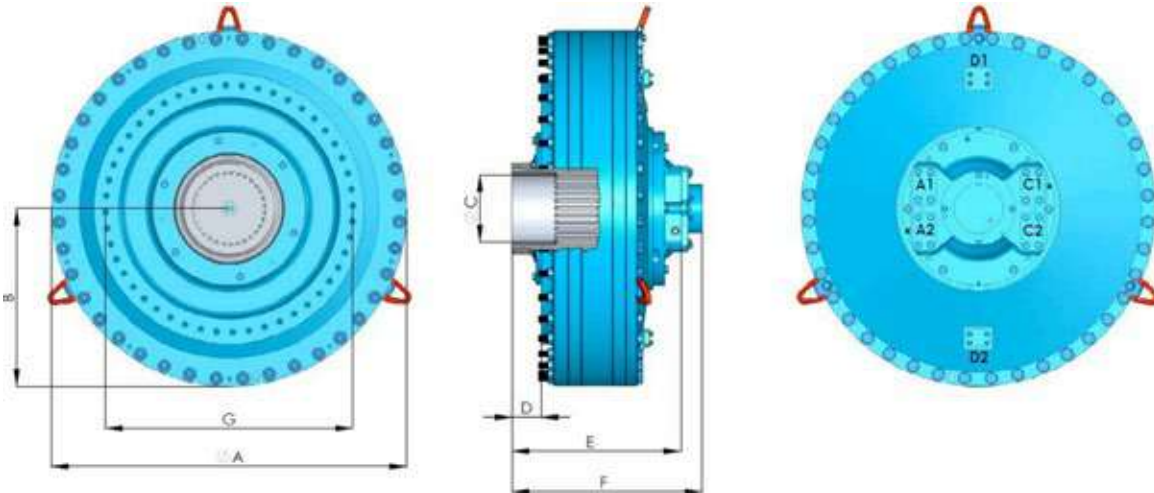

Motor	ØA (mm)	B (mm)	ØC (mm-DIN 5480)	D (mm)	E (mm)	F (mm)	ØG (mm) Mounting Dimensions for Torque Arm or Bracket	Weight Kg	Main conn A1, A2, C1, C2	Drain conn D1, D2
HMA 20	1100	550	N200x5x30x38x9H	115	593	725	M24X 48Nos THRU HOLES, AT PCD 870±0.1	2050	SAE 2"	1-1/4"SAE
HMA 25	1100	550	N200x5x30x38x9H	115	593	725		2050	SAE 2"	1-1/4"SAE
HMA 30	1100	550	N200x5x30x38x9H	115	593	725		2050	SAE 2"	1-1/4"SAE
HMA 36	1100	550	N260x5x30x50x9H	133	611	743		2000	SAE 2"	1-1/4"SAE
HMA 50	1250	625	N260x5x30x50x9H	133	650	780		2200	SAE 2"	1-1/4"SAE

\* Technical dimensions are subject to change without prior notice

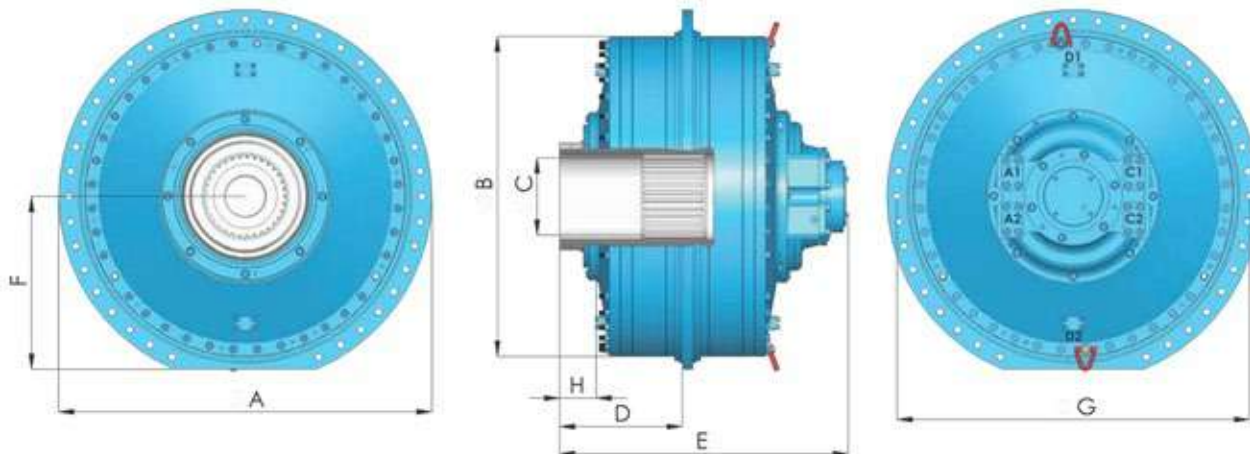

Motor	ØA (mm)	ØB (mm)	ØC DIN5480	D (mm)	E (mm)	F (mm)	ØG(mm) Mounting Dimensions for Torque Arm	H (mm)	Weight Kg	Main conn A1, A2, C1, C2	Drain conn D1, D2
HMA 100-70	1460	1250	N360x8x30x44x9H	470	1145	675	Ø26X43Nos MOUNTING HOLES AT PCD 1380±0.1	141	4100	SAE 2"	1-1/4"SAE
HMA 100	1460	1250	N360x8x30x44x9H	470	1295	675		291	4300	SAE 2"	1-1/4"SAE

\* Technical dimensions are subject to change without prior notice

# HD SERIES

DIMENSIONS:

## MOTORS WITH FEMALE SPLINES & BRAKE

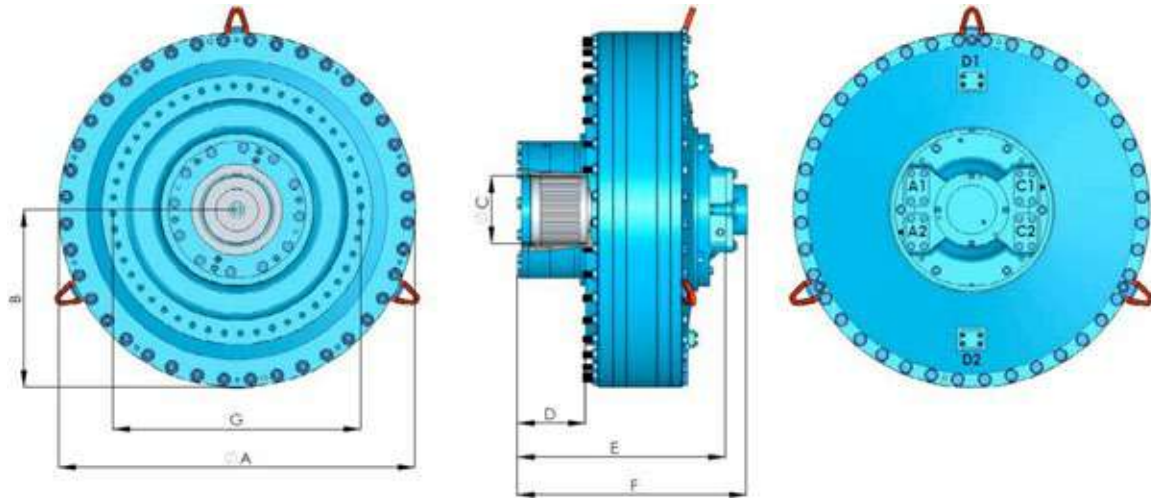

Motor	ØA (mm)	B (mm)	ØC (mm-DIN 5480)	D (mm)	E (mm)	F (mm)	ØG (mm) Mounting Dimensions for Torque Arm or Bracket	Weight Kg	Main conn A1, A2, C1, C2	Drain conn D1, D2
HMB 20	1100	550	N200x5x30x38x9H	298	777	908	M24X 48Nos THRU HOLES, AT PCD 870±0.1	2550	SAE 2"	1-1/4"SAE
HMB 25	1100	550	N200x5x30x38x9H	298	777	908		2450	SAE 2"	1-1/4"SAE
HMB 30	1100	550	N260x5x30x38x9H	298	777	908		2400	SAE 2"	1-1/4"SAE
HMB 36	1100	550	N260x5x30x50x9H	298	777	908		2400	SAE 2"	1-1/4"SAE

\* Technical dimensions are subject to change without prior notice

# VHD SERIES

MOTOR FRAME SIZE	SPECIFICATIONS					
	DISP.(*) PER REV	TORQUE (THEORETICAL)	TORQUE MAX	SPEED RATED	SPEED MAX**	PRESSURE RATED
METRIC	cm <sup>3</sup> /Rev	Nm/Bar	Nm	RPM	RPM	Bar
HMA 150	150200	2390	788700	12	16	350
HMA 200	201000	3198	1055340	12	16	350
HMA 250	251000	3993	1317690	9	12	350

## DIMENSIONS:

## MOTORS WITH SHRINK DISC COUPLINGS

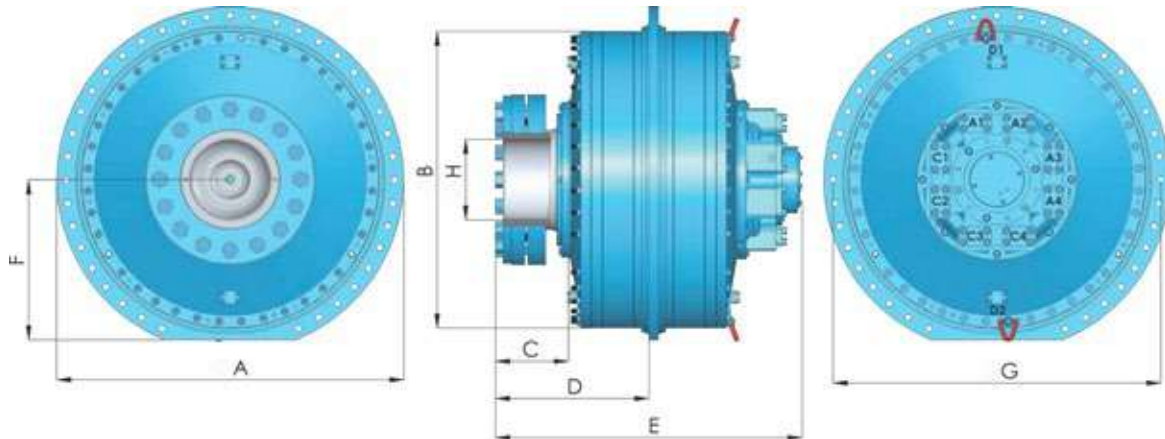

Motor	ØA (mm)	ØB (mm)	C (mm)	D (mm)	E (mm)	F (mm)	G (mm) Mounting Dimensions for Torque Arm	ØH (mm)	Weight Kg	Main conn A1, A2, A3, A4 C1, C2, C3, C4	Drain conn D1, D2
HMA 150	1560	1350	368	670	1300	715	Ø26X43Nos MOUNTING HOLES, AT PCD 1480±0.2	360	4950	SAE 2"	1-1/4"SAE
HMA 200	1560	1350	390	670	1300	715		460	5450	SAE 2"	1-1/4"SAE

\* Technical dimensions are subject to change without prior notice

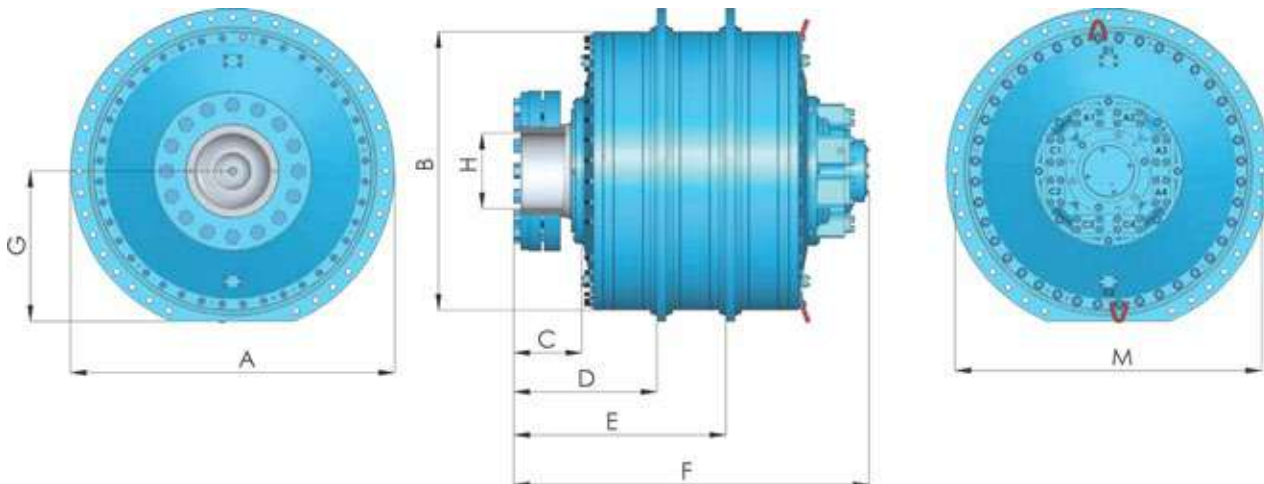

Motor	ØA (mm)	ØB (mm)	C (mm)	D (mm)	E (mm)	F (mm)	G (mm)	ØH (mm)	ØM(mm) Mounting Dimensions for Torque Arm	Weight Kg	Main conn A1, A2, A3, A4 C1, C2, C3, C4	Drain conn D1, D2
HMA 250	1560	1350	368	690	950	1580	715	460	Ø26X43Nos MOUNTING HOLES AT PCD 1480±0.2	6900	SAE 2"	1-1/4"SAE

\* Technical dimensions are subject to change without prior notice



# VHD SERIES

## DIMENSIONS: HOLLOW SHAFT MOTORS WITH FEMALE SPLINES

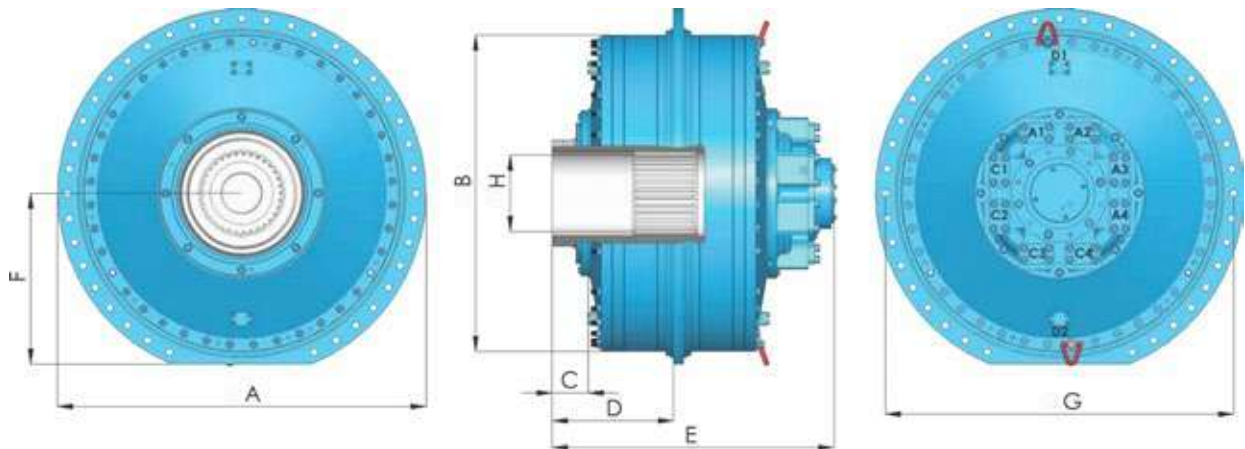

Motor	ØA (mm)	ØB (mm)	C (mm)	D (mm)	E (mm)	F (mm)	ØG (mm) Mounting Dimensions for Torque Arm	ØH DIN5480	Weight Kg	Main conn A1, A2, A3, A4 C1, C2, C3, C4	Drain conn D1, D2
HMA 150	1560	1350	168	470	1100	715	Ø26X43Nos MOUNTING HOLES, AT PCD 1480±0.2	N360x8x30x44x9H	4950	SAE 2"	1-1/4"SAE
HMA 200	1560	1350	210	513	1144	715		N440x8x30x54x9H	5225	SAE 2"	1-1/4"SAE

\* Technical dimensions are subject to change without prior notice

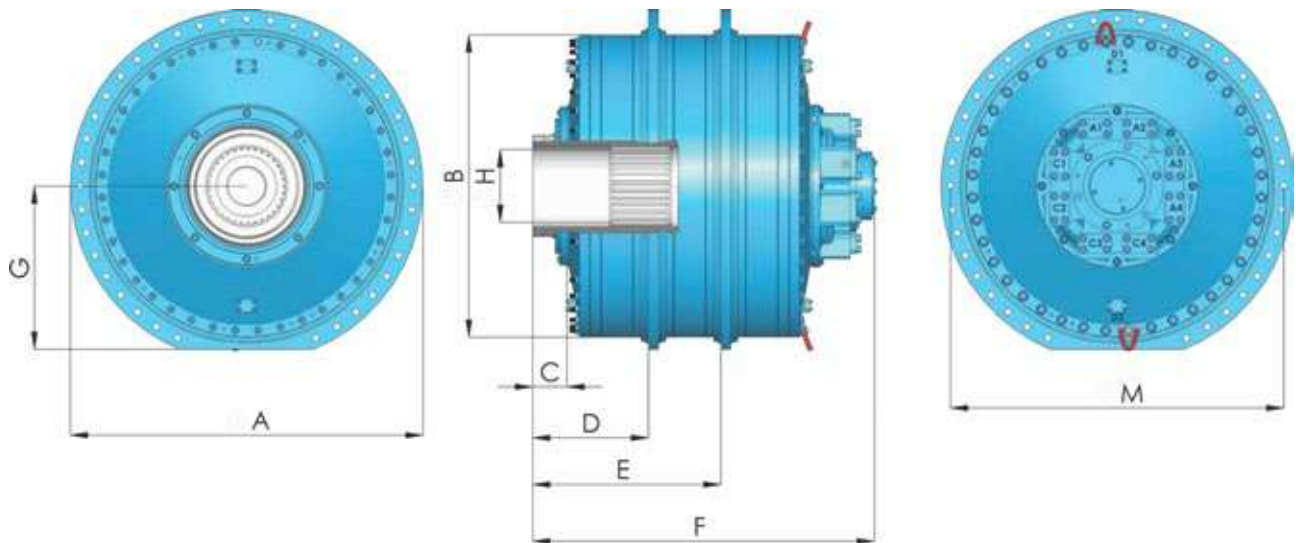

Motor	ØA (mm)	ØB (mm)	C (mm)	D (mm)	E (mm)	F (mm)	G (mm)	ØH DIN5480	ØM(mm) Mounting Dimensions for Torque Arm	Weight Kg	Main conn A1, A2, A3, A4 C1, C2, C3, C4	Drain conn D1, D2
HMA 250	1560	1350	268	570	830	1460	715	N440x8x30x54x9H	Ø26X43Nos MOUNTING HOLES AT PCD 1480±0.2	6100	SAE 2"	1-1/4"SAE

\* Technical dimensions are subject to change without prior notice

# MD SERIES



**SCHRODER MD Series** hydraulic motors are designed for high power and high-speed applications. Wagon Tippers, Shredders and Slew Drives are typically driven by MD Series motors. In addition, these motors are well suited for use on Feeder Breakers, Ball Mills and Bowl Mills. Optionally, an integral brake can be fitted on the front end of the motor shaft.

Motor displacements range from 12 lit/rev. to 15 lit/rev. providing a wide variety of precise hydraulic motor and pump combinations. These motors can take heavy shock loads due to the incorporation of a robust front bearing arrangement.

## OPTIONS

- CUSTOMIZED / DOUBLE SHAFT
- INTEGRAL MULTI-PLATE DISC BRAKE
- HIGH SPEED VERSIONS
- CORROSION RESISTANT MATERIAL
- VARIOUS SIZED THROUGH-HOLE SHAFTS
- CUSTOM FINISH
- DEEP WATER SUBMERSIBLE
- NON MAGNETIC MATERIAL
- DUAL DISPLACEMENT
- SHAFT OR FLANGE MOUNTING

## FEATURES

- LONG LIFE
- HIGH MECHANICAL EFFICIENCY
- CONSTANT TORQUE OUTPUT
- SMOOTH LOW SPEED PERFORMANCE <1RPM
- RESISTANCE TO THERMAL SHOCK
- DOUBLE SHAFT SEALING
- SHRINK DISC COUPLING
- SHOCK RESISTANCE
- LOW NOISE



MOTOR FRAME SIZE	SPECIFICATIONS					
	DISP.(*) PER REV	TORQUE (THEORETICAL)	TORQUE MAX	SPEED RATED	SPEED MAX**	PRESSURE RATED
METRIC	cm <sup>3</sup> /Rev	Nm/Bar	Nm	RPM	RPM	Bar
HM 12	12760	200	66000	75	100	350
HM 13.5	13540	215	70950	75	110	350
HM 15	15160	241	79530	70	100	350

\*\*High speed version upon request

\* Any other displacement upon request

# MD SERIES

DIMENSIONS:

## MOTORS WITH SHRINK DISC COUPLINGS

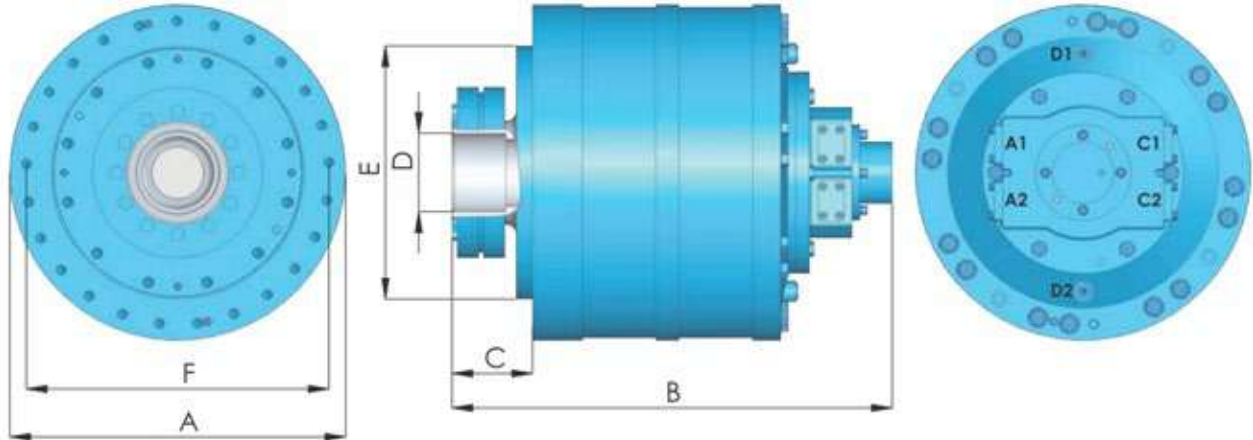

Motor	ØA (mm)	B (mm)	C (mm)	ØD (mm)	ØE (mm)	ØF (mm) Mounting Dimensions for Torque Arm or Bracket	Weight Kg	Main conn A1, A2, C1, C2	Drain conn D1, D2
HMA 12	667	862	176	160	490	M20 X 30MM DEEP 25 HOLES AT PCD 587±0.1	1040	SAE 1-1/4"	1"BSP
HMA 13.5	667	862	176	160	490		1010	SAE 1-1/4"	1"BSP
HMA 15	667	862	176	180	490		960	SAE 1-1/4"	1"BSP

\* Technical dimensions are subject to change without prior notice

## MOTORS WITH SHRINK DISC COUPLINGS & BRAKE

## MD SERIES

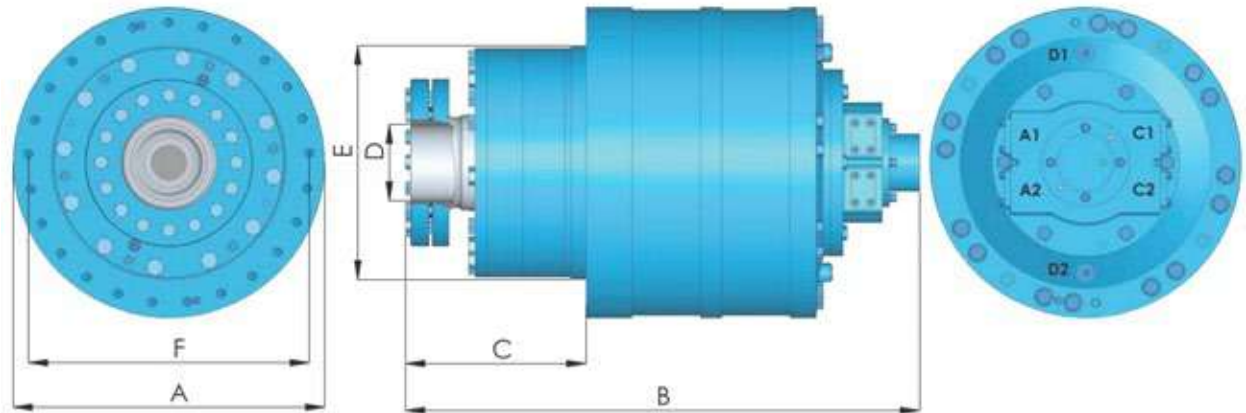

Motor	ØA (mm)	B (mm)	C (mm)	ØD (mm)	ØE (mm)	ØF (mm) Mounting Dimensions for Torque Arm or Bracket	Weight Kg	Main conn A1, A2, C1, C2	Drain conn D1, D2
HMA 12	667	1069	383	160	490	M20 X 30MM DEEP 25 HOLES AT PCD 587±0.1	1040	SAE 1-1/4"	1"BSP
HMA 13.5	667	1069	383	160	490		1010	SAE 1-1/4"	1"BSP
HMA 15	667	1069	383	180	490		960	SAE 1-1/4"	1"BSP

\* Technical dimensions are subject to change without prior notice

# MD SERIES

## DIMENSIONS

### HOLLOW SHAFT MOTORS WITH FEMALE SPLINES

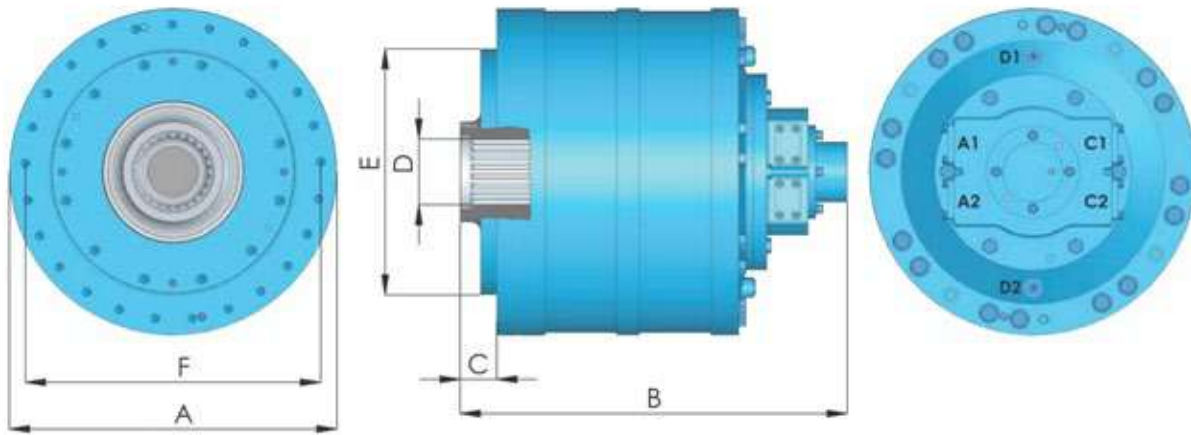

Motor	ØA (mm)	B (mm)	C (mm)	ØD (mm-DIN 5480)	ØE (mm)	ØF (mm) Mounting Dimensions for Torque Arm or Bracket	Weight Kg	Main conn A1, A2, C1, C2	Drain conn D1, D2
HMA 12	667	767	81	N150x5x30x28x9H	490	M20 X 30MM DEEP 25 HOLES AT PCD 587±0.1	960	SAE 1-1/ 4"	1"BSP
HMA 13.5	667	767	81	N150x5x30x28x9H	490		960	SAE 1-1/ 4"	1"BSP
HMA 15	667	767	81	N200x5x30x38X9H	490		960	SAE 1-1/ 4"	1"BSP

\* Technical dimensions are subject to change without prior notice

### HOLLOW SHAFT MOTORS WITH FEMALE SPLINES & BRAKE

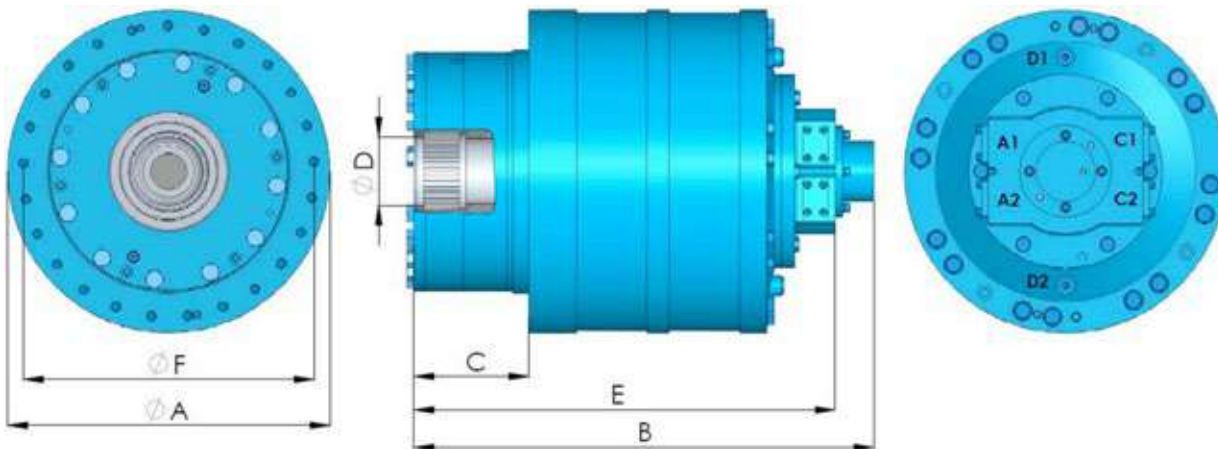

Motor	ØA (mm)	B (mm)	C (mm)	ØD (mm-DIN 5480)	E (mm)	ØF (mm) Mounting Dimensions for Torque Arm or Bracket	Weight Kg	Main conn A1, A2, C1, C2	Drain conn D1, D2
HMA 12	667	927	241	N150x5x30x28x9H	858	M20 X 30MM DEEP 25 HOLES AT PCD 587±0.1	1100	SAE 1-1/ 4"	1"BSP
HMA 13.5	667	927	241	N150x5x30x28x9H	858		1100	SAE 1-1/ 4"	1"BSP
HMA 15	667	927	241	N200x5x30x38X9H	858		1100	SAE 1-1/ 4"	1"BSP

\* Technical dimensions are subject to change without prior notice

# LD SERIES



**SCHRODER LD Series** hydraulic motors are developed for high-speed applications and perform with high efficiency in tough conditions. They are used mainly in Rail Car Pushers, Side Arm Chargers and Wagon Tiplers, but are also highly suitable for Belt Conveyor applications. Their light, compact size, and ease of installation make these motors also equally suited for mobile applications. Several mounting options are available. The axial load capacity of our LD Series motors is very high, making them very suitable for use in Paddle Feeder Wheel Drives and other applications where axial forces are high. An integral parking brake at the front of the motor ensures high holding torque.

## OPTIONS

- CUSTOMIZED / DOUBLE SHAFT
- INTEGRAL MULTI-PLATE DISC BRAKE
- HIGH SPEED VERSIONS
- CORROSION RESISTANT MATERIAL
- VARIOUS SIZED THROUGH-HOLE SHAFT
- CUSTOM FINISH
- DEEP WATER SUBMERSIBLE
- NON MAGNETIC MATERIAL
- DUAL DISPLACEMENT
- SHAFT OR FLANGE MOUNTING

## FEATURES

- LONG LIFE
- HIGH MECHANICAL EFFICIENCY
- CONSTANT TORQUE OUTPUT
- SMOOTH LOW SPEED PERFORMANCE <1RPM
- RESISTANCE TO THERMAL SHOCK
- DOUBLE SHAFT SEALING
- SHRINK DISC COUPLING
- SHOCK RESISTANCE
- LOW NOISE



MOTOR FRAME SIZE	SPECIFICATIONS					
	DISP.(*) PER REV	TORQUE (THEORETICAL)	TORQUE MAX	SPEED RATED	SPEED MAX**	PRESSURE RATED
METRIC	cm <sup>3</sup> /Rev	Nm/Bar	Nm	RPM	RPM	Bar
HM 3.2	3270	51	16830	110	180	350
HM 3.9	3930	62	20460	110	180	350
HM 5.0	5070	81	26730	140	220	350
HM 6.0	6180	98	32406	120	190	350
HM 7.5	6580	104	34320	100	160	350
HMA 9.0	7530	120	39600	100	160	350

\*\*High speed version upon request

\* Any other displacement upon request

# LD SERIES

## DIMENSIONS:

## MOTORS WITH SHRINK DISC COUPLINGS

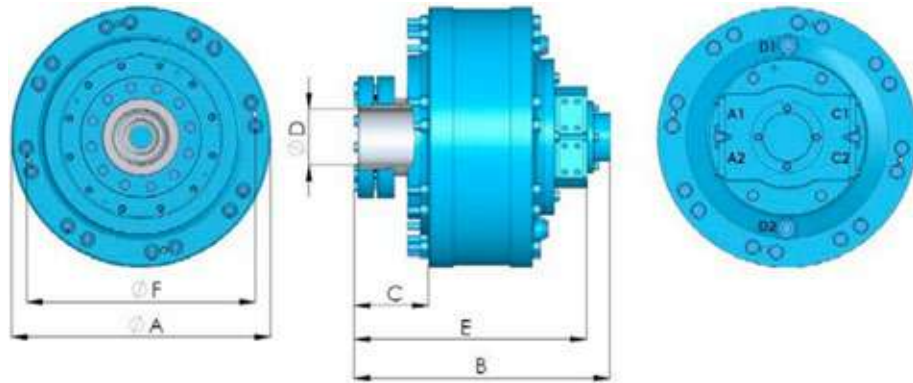

Motor	ØA (mm)	B (mm)	C (mm)	ØD (mm)	E (mm)	ØF (mm) Mounting Dimensions for Torque Arm or Bracket	Weight Kg	Main Conn A1, A2, C1, C2	Drain Conn D1, D2
HMA 3.2	667	633	168	120	524	8 SETS x 2 Nos OF HOLES, M20 AT PCD 587 ± 0.1	650	SAE 1-1/ 4"	3/4"BSP
HMA 3.9	667	633	168	120	524		650	SAE 1-1/ 4"	3/4"BSP
HMA 5.0	667	633	168	120	524		650	SAE 1-1/ 4"	3/4"BSP
HMA 6.0	667	633	168	140	524		700	SAE 1-1/ 4"	1"BSP
HMA 6.5	667	633	168	140	524		700	SAE 1-1/ 4"	1"BSP
HMA 7.5	667	633	168	140	524		700	SAE 1-1/ 4"	1"BSP
HMA 9.0	667	650	168	140	581	M20 X 30 DEEP 25 HOLES PCD 587± 0.1	800	SAE 1-1/ 4"	1"BSP

\* Technical dimensions are subject to change without prior notice

## MOTORS WITH SHRINK DISC COUPLINGS & BRAKE

## LD SERIES

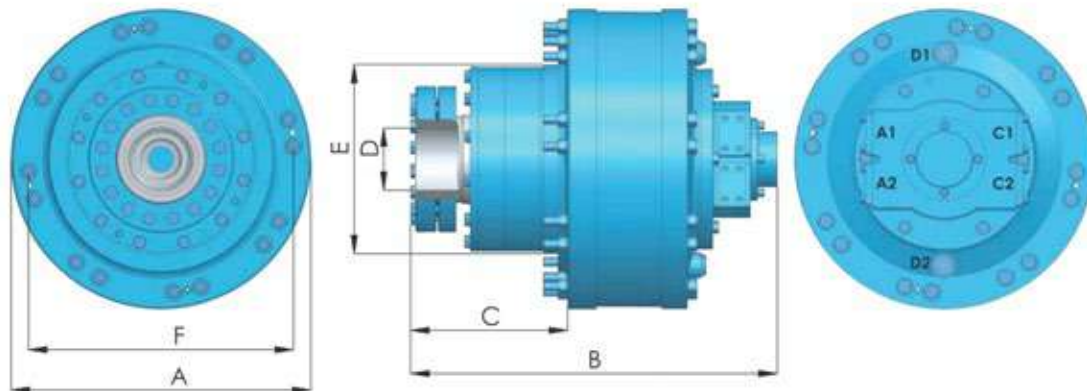

Motor	ØA (mm)	B (mm)	C (mm)	ØD (mm)	E (mm)	ØF (mm) Mounting Dimensions for Torque Arm or Bracket	Weight Kg	Main Conn A1, A2, C1, C2	Drain Conn D1, D2
HMA 3.2	667	806	341	120	490	8 SETS x 2 Nos OF HOLES, M20 AT PCD 587 ± 0.1	790	SAE 1-1/ 4"	3/4"BSP
HMA 3.9	667	806	341	120	490		790	SAE 1-1/ 4"	3/4"BSP
HMA 5.0	667	806	341	120	490		790	SAE 1-1/ 4"	3/4"BSP
HMA 6.0	667	806	341	140	490		890	SAE 1-1/ 4"	1"BSP
HMA 6.5	667	806	341	140	490		890	SAE 1-1/ 4"	1"BSP
HMA 7.5	667	806	341	140	490		890	SAE 1-1/ 4"	1"BSP
HMA 9.0	667	835	341	140	490	M20 X 30 DEEP 25 HOLES PCD 587± 0.1	900	SAE 1-1/ 4"	1"BSP

\* Technical dimensions are subject to change without prior notice

## HOLLOW SHAFT MOTORS WITH FEMALE SPLINES

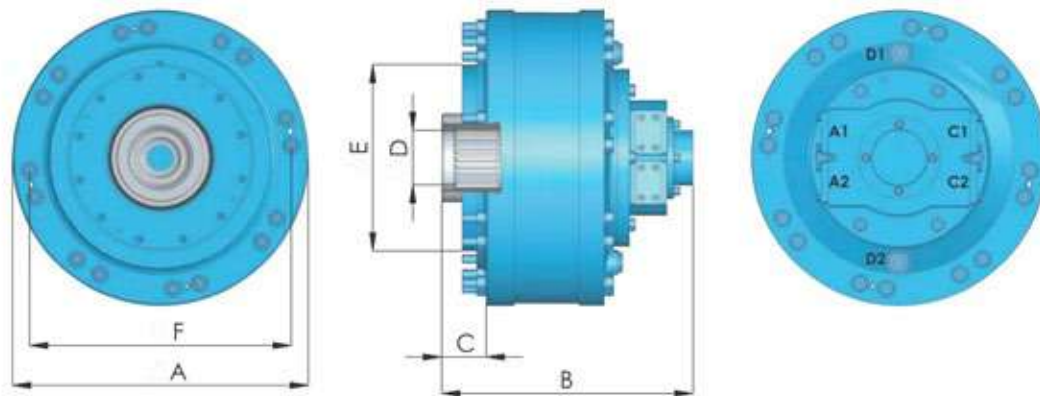

Motor	ØA (mm)	B (mm)	C (mm)	ØD (mm-DIN 5480)	ØE (mm)	ØF (mm) Mounting Dimensions for Torque Arm or Bracket	Weight Kg	Main conn A1, A2, C1, C2	Drain conn D1, D2
HMA 3.2	667	533	68	N120x5x30x22x9H	490	8 SETS x 2 Nos OF HOLES M20 AT PCD 587 ± 0.1	550	SAE 1-1/ 4"	3/4" BSP
HMA 3.9	667	533	68	N120x5x30x22x9H	490		550	SAE 1-1/ 4"	3/4" BSP
HMA 5.0	667	533	68	N120x5x30x22x9H	490		550	SAE 1-1/ 4"	3/4" BSP
HMA 6.0	667	533	68	N140x5x30x26x9H	490		600	SAE 1-1/ 4"	1" BSP
HMA 6.5	667	533	68	N140x5x30x26x9H	490		600	SAE 1-1/ 4"	1" BSP
HMA 7.5	667	533	68	N140x5x30x26x9H	490		600	SAE 1-1/ 4"	1" BSP
HMA 9.0	667	562	68	N140x5x30x26x9H	490		M20 X 30 DEEP 25 HOLES PCD 587± 0.1	700	SAE 1-1/ 4"

\* Technical dimensions are subject to change without prior notice

## HOLLOW SHAFT MOTORS WITH FEMALE SPLINES & BRAKE

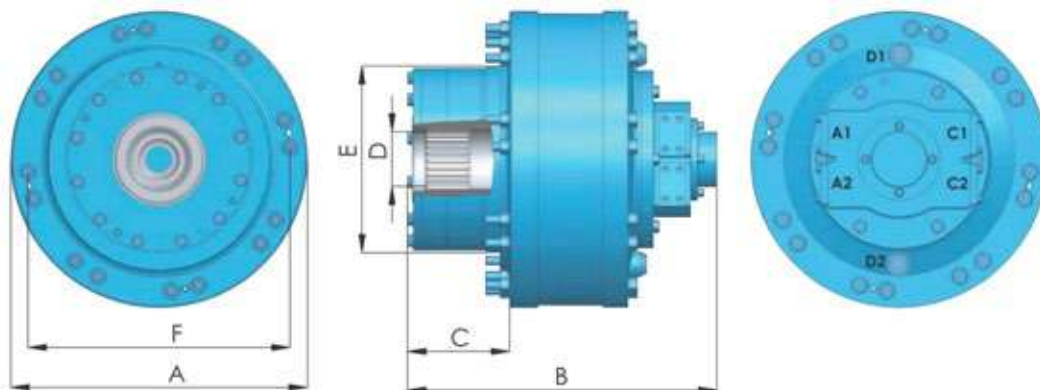

Motor	ØA (mm)	B (mm)	C (mm)	ØD (mm-DIN 5480)	ØE (mm)	ØF (mm) Mounting Dimensions for Torque Arm or Bracket	Weight Kg	Main conn A1, A2, C1, C2	Drain conn D1, D2
HMA 3.2	667	697	232	N120x5x30x22x9H	490	8 SETS x 2 Nos OF HOLES M20 AT PCD 587 ± 0.1	750	SAE 1-1/ 4"	3/4" BSP
HMA 3.9	667	697	232	N120x5x30x22x9H	490		750	SAE 1-1/ 4"	3/4" BSP
HMA 5.0	667	697	232	N120x5x30x22x9H	490		750	SAE 1-1/ 4"	3/4" BSP
HMA 6.0	667	697	232	N140x5x30x26x9H	490		850	SAE 1-1/ 4"	1" BSP
HMA 6.5	667	697	232	N140x5x30x26x9H	490		850	SAE 1-1/ 4"	1" BSP
HMA 7.5	667	697	232	N140x5x30x26x9H	490		850	SAE 1-1/ 4"	1" BSP
HMA 9.0	667	738	232	N140x5x30x26x9H	490		M20 X 30 DEEP 25 HOLES PCD 587± 0.1	900	SAE 1-1/ 4"

\* Technical dimensions are subject to change without prior notice

# 820 SERIES

**HIGH SPEED – HIGH BRAKING**

**SCHRODER 820 Series Hydraulic Motors** provide high torque for high-speed applications and incorporate the “high-flow” distribution system. These motors are extensively used for Wagon tippler and high inclination conveyors, where a high brake torque is required. Hydraulic braking (static) up to 16000 kg/m is achievable, which also makes them an ideal choice for high braking torque applications. The motor displacements available range from 10 lit/rev. up to 30 lit/rev. with heavy shock load resistance due to the incorporation of a robust front bearing arrangement. An integral parking brake option is also available to ensure high holding torque.

## OPTIONS

- CUSTOMIZED / DOUBLE SHAFT
- INTEGRAL MULTI-PLATE DISC BRAKE
- HIGH SPEED VERSIONS
- CORROSION RESISTANT MATERIAL
- VARIOUS SIZED THROUGH-HOLE SHAFTS
- CUSTOM FINISH
- DEEP WATER SUBMERSIBLE
- NON MAGNETIC MATERIAL
- DUAL DISPLACEMENT
- SHAFT OR FLANGE MOUNTING

## FEATURES

- LONG LIFE
- HIGH MECHANICAL EFFICIENCY
- CONSTANT TORQUE OUTPUT
- SMOOTH LOW SPEED PERFORMANCE <1RPM
- RESISTANCE TO THERMAL SHOCK
- DOUBLE SHAFT SEALING
- SHRINK DISC COUPLING
- SHOCK RESISTANCE
- LOW NOISE



MOTOR FRAME SIZE	SPECIFICATIONS					
	DISP.(*) PER REV	TORQUE (THEORETICAL)	TORQUE MAX	SPEED RATED	SPEED MAX**	PRESSURE RATED
METRIC	cm <sup>3</sup> /Rev	Nm/Bar	Nm	RPM	RPM	Bar
HM 10	10200	162	56700	105	120	350
HM 13.5	13540	215	75250	85	115	350
HM 15	15160	241	84350	70	100	350
HM 17.5	17500	286	100100	71	100	350
HM 20	20380	324	113400	68	98	350
HM 25	25320	402	140700	70	90	350
HM 30	30580	486	170100	60	80	350

\*\*High speed version upon request

\* Any other displacement upon request



# 820 SERIES

## DIMENSIONS

### MOTORS WITH SHRINK DISC COUPLING

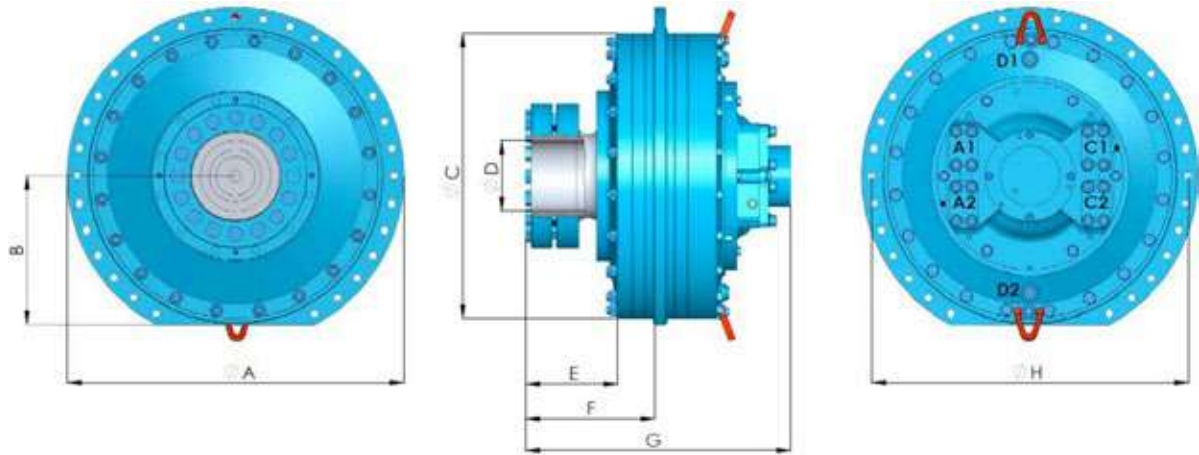

Motor	ØA (mm)	B (mm)	ØC (mm)	ØD (mm)	E (mm)	F (mm)	G (mm)	ØH (mm) Mounting Dimensions for Torque Arm or Bracket	Weight Kg	Main Conn A1, A2, C1, C2	Drain Conn D1, D2
HMA 10	970	428	820	160	204	312	746	31Nos of Ø22THRU HOLES AT PCD 910±0.1	1510	SAE 2"	1-1/4"BSP
HMA 13.5	970	428	820	160	204	312	746		1490	SAE 2"	1-1/4"BSP
HMA 15	970	428	820	180	204	312	746		1400	SAE 2"	1-1/4"BSP

\* Technical dimensions are subject to change without prior notice

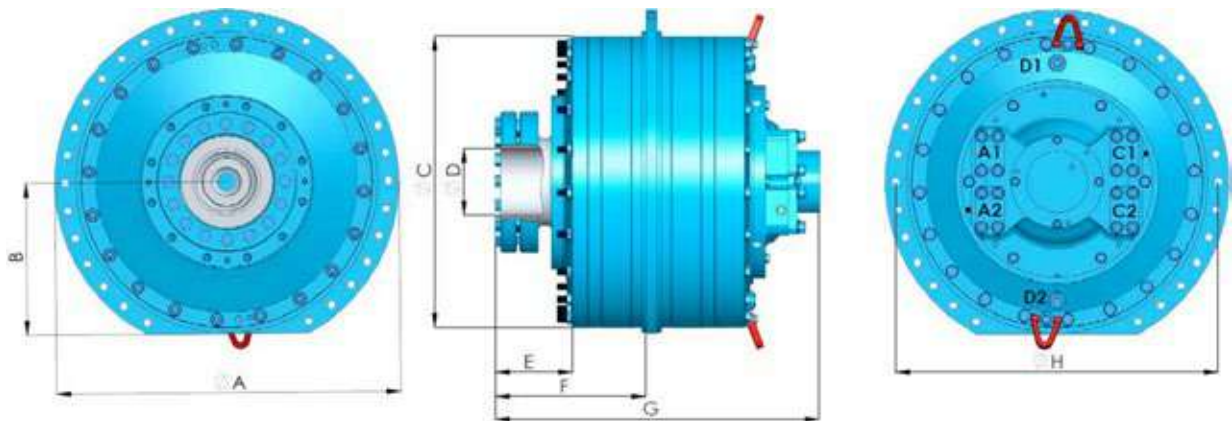

Motor	ØA (mm)	B (mm)	ØC (mm)	ØD (mm)	E (mm)	F (mm)	G (mm)	ØH (mm) Mounting Dimensions for Torque Arm or Bracket	Weight Kg	Main Conn A1, A2, C1, C2	Drain Conn D1, D2
HMA 17.5	970	428	820	180	215	422	911	31Nos of Ø22THRU HOLES AT PCD 910±0.1	1600	SAE 2"	1-1/4"BSP
HMA 20	970	428	820	200	215	422	911		1550	SAE 2"	1-1/4"BSP
HMA 25	970	428	820	200	215	422	911		1530	SAE 2"	1-1/4"BSP
HMA 30	970	428	820	200	215	422	911		1510	SAE 2"	1-1/4"BSP

\* Technical dimensions are subject to change without prior notice

# 820 SERIES

## DIMENSIONS

### MOTORS WITH SHRINK DISC COUPLINGS & BRAKE

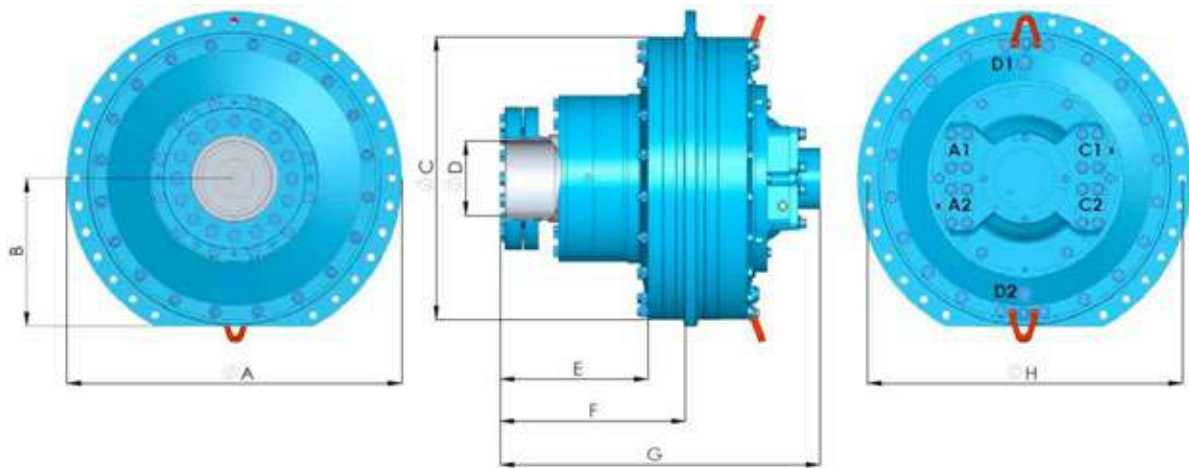

Motor	ØA (mm)	B (mm)	ØC (mm)	ØD (mm)	E (mm)	F (mm)	G (mm)	ØH (mm) Mounting Dimensions for Torque Arm or Bracket	Weight Kg	Main Conn A1, A2, C1, C2	Drain Conn D1, D2
HMA 10	970	428	820	160	400	530	933	31Nos of Ø22THRU HOLES AT PCD 910±0.1	1700	SAE 2"	1-1/4"BSP
HMA 13.5	970	428	820	160	400	530	933		1700	SAE 2"	1-1/4"BSP
HMA 15	970	428	820	180	400	530	933		1800	SAE 2"	1-1/4"BSP

\* Technical dimensions are subject to change without prior notice

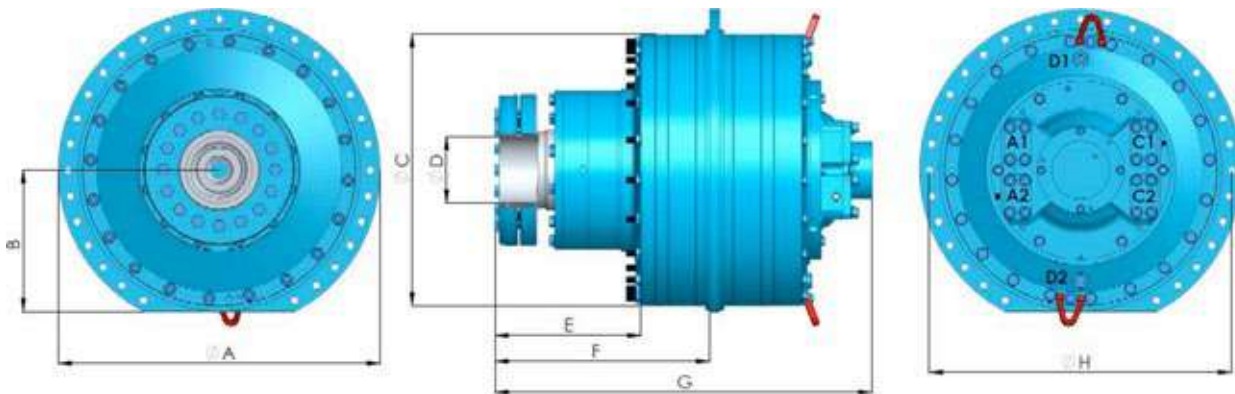

Motor	ØA (mm)	B (mm)	ØC (mm)	ØD (mm)	E (mm)	F (mm)	G (mm)	ØH (mm) Mounting Dimensions for Torque Arm or Bracket	Weight Kg	Main Conn A1, A2, C1, C2	Drain Conn D1, D2
HMA 17.5	970	428	820	180	400	635	1124	31Nos of Ø22THRU HOLES AT PCD 910±0.1	1900	SAE 2"	1-1/4"BSP
HMA 20	970	428	820	200	400	635	1124		1900	SAE 2"	1-1/4"BSP
HMA 25	970	428	820	200	400	635	1124		2000	SAE 2"	1-1/4"BSP
HMA 30	970	428	820	200	400	635	1124		2000	SAE 2"	1-1/4"BSP

\* Technical dimensions are subject to change without prior notice

# 820 SERIES

## DIMENSIONS

### HOLLOW SHAFT MOTORS WITH FEMALE SPLINES

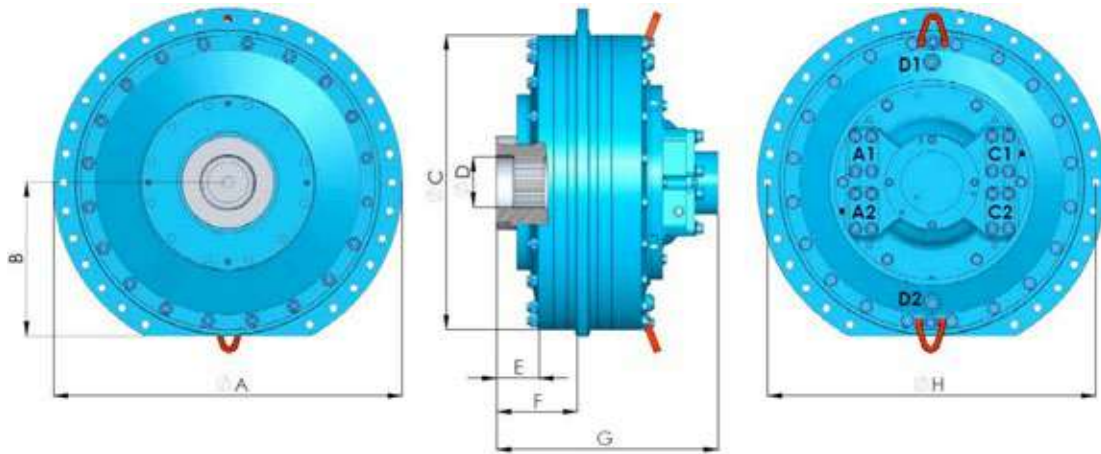

Motor	ØA (mm)	B (mm)	ØC (mm)	ØD (mm-DIN 5480)	E (mm)	F (mm)	G (mm)	ØH (mm) Mounting Dimensions for Torque Arm or Bracket	Weight Kg	Main conn A1, A2, C1, C2	Drain conn D1, D2
HMA 10	970	428	820	N150x5x30x28x9H	118	226	660	31Nos of Ø22 THRU HOLES AT PCD 910±0.1	1250	SAE 2"	1-1/4"SAE
HMA 13.5	970	428	820	N150x5x30x28x9H	118	226	660		1300	SAE 2"	1-1/4"SAE
HMA 15	970	428	820	N200x5x30x38x9H	118	226	660		1400	SAE 2"	1-1/4"SAE

\* Technical dimensions are subject to change without prior notice

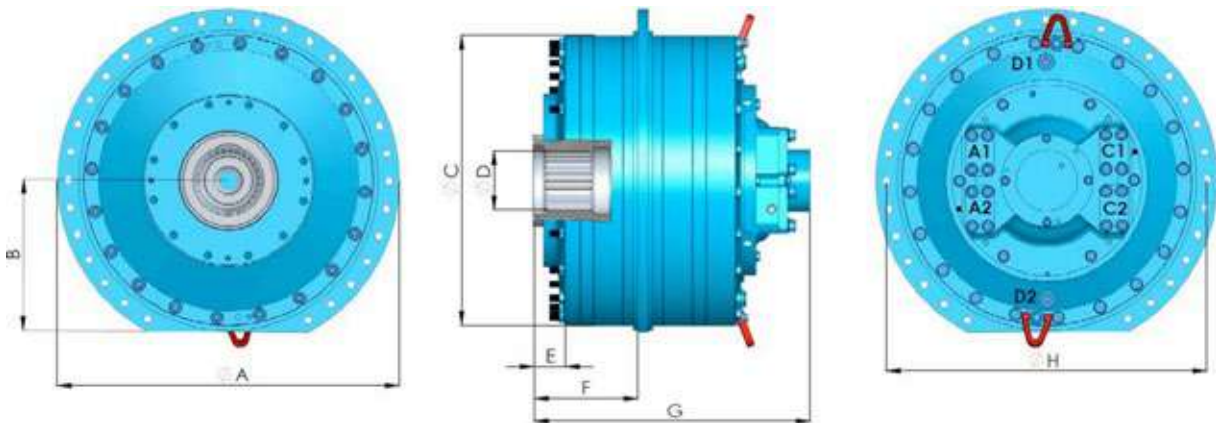

Motor	ØA (mm)	B (mm)	ØC (mm)	ØD (mm-DIN 5480)	E (mm)	F (mm)	G (mm)	ØH (mm) Mounting Dimensions for Torque Arm or Bracket	Weight Kg	Main conn A1, A2, C1, C2	Drain conn D1, D2
HMA 17.5	970	428	820	N200x5x30x38x9H	60	294	784	31Nos of Ø22 THRU HOLES AT PCD 910±0.1	1300	SAE 2"	1-1/4"SAE
HMA 20	970	428	820	N200x5x30x38x9H	60	294	784		1300	SAE 2"	1-1/4"SAE
HMA 25	970	428	820	N200x5x30x38x9H	60	294	784		1370	SAE 2"	1-1/4"SAE
HMA 30	970	428	820	N260x5x30x50x9H	60	294	784		1350	SAE 2"	1-1/4"SAE

\* Technical dimensions are subject to change without prior notice

# 820 SERIES

## DIMENSIONS

### HOLLOW SHAFT MOTORS WITH FEMALE SPLINES & BRAKE

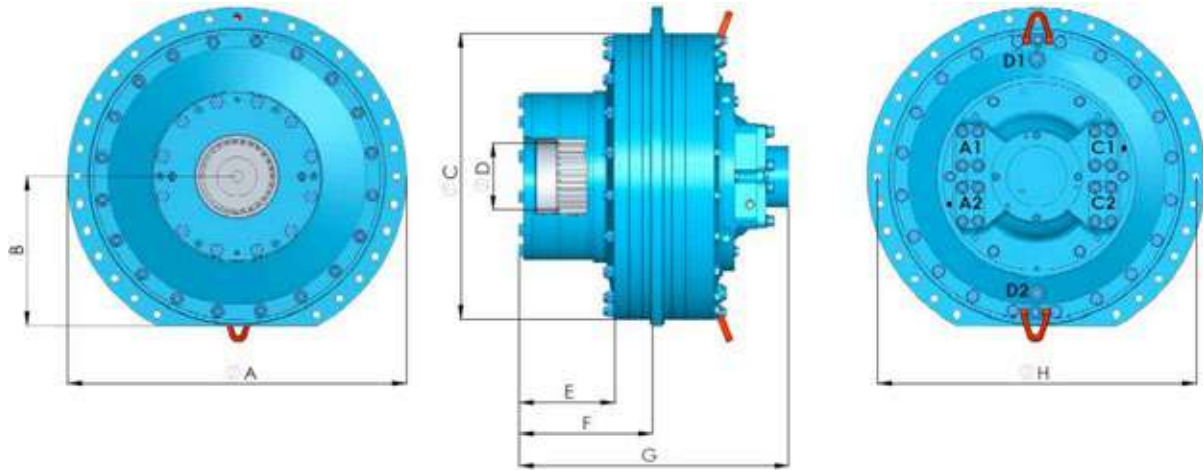

Motor	ØA (mm)	B (mm)	ØC (mm)	ØD (mm-DIN 5480)	E (mm)	F (mm)	G (mm)	ØH (mm) Mounting Dimensions for Torque Arm or Bracket	Weight Kg	Main conn A1, A2, C1, C2	Drain conn D1, D2
HMB 10	970	428	820	N150x5x30x28x9H	271	226	813	31Nos of Ø22 THRU HOLES AT PCD 910±0.1	1550	SAE 2"	1-1/ 4"SAE
HMB 13.5	970	428	820	N150x5x30x28x9H	271	226	813		1500	SAE 2"	1-1/ 4"SAE
HMB 15	970	428	820	N200x5x30x38x9H	271	226	813		1450	SAE 2"	1-1/ 4"SAE

\* Technical dimensions are subject to change without prior notice

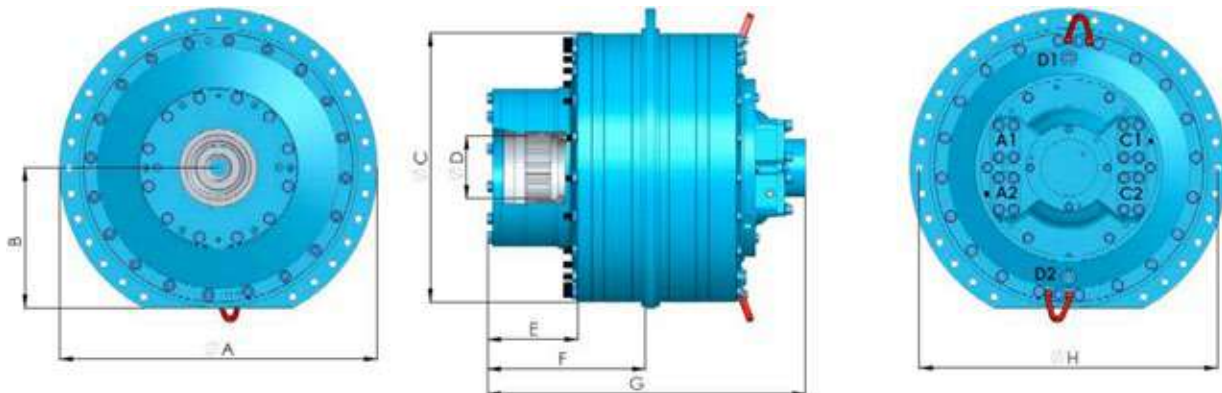

Motor	ØA (mm)	B (mm)	ØC (mm)	ØD (mm-DIN 5480)	E (mm)	F (mm)	G (mm)	ØH (mm) Mounting Dimensions for Torque Arm or Bracket	Weight Kg	Main conn A1, A2, C1, C2	Drain conn D1, D2
HMA 17.5	970	428	820	N200x5x30x38x9H	260	470	975	31Nos of Ø22 THRU HOLES AT PCD 910±0.1	1700	SAE 2"	1-1/ 4"SAE
HMA 20	970	428	820	N200x5x30x38x9H	271	478	967		1650	SAE 2"	1-1/ 4"SAE
HMA 25	970	428	820	N200x5x30x38x9H	271	478	967		1650	SAE 2"	1-1/ 4"SAE
HMA 30	970	428	820	N200x5x30x38x9H	271	478	967		1650	SAE 2"	1-1/ 4"SAE

\* Technical dimensions are subject to change without prior notice

# 820 SERIES

## DIMENSIONS

### 15-LITER SPECIAL - FOR WAGON TIPLER

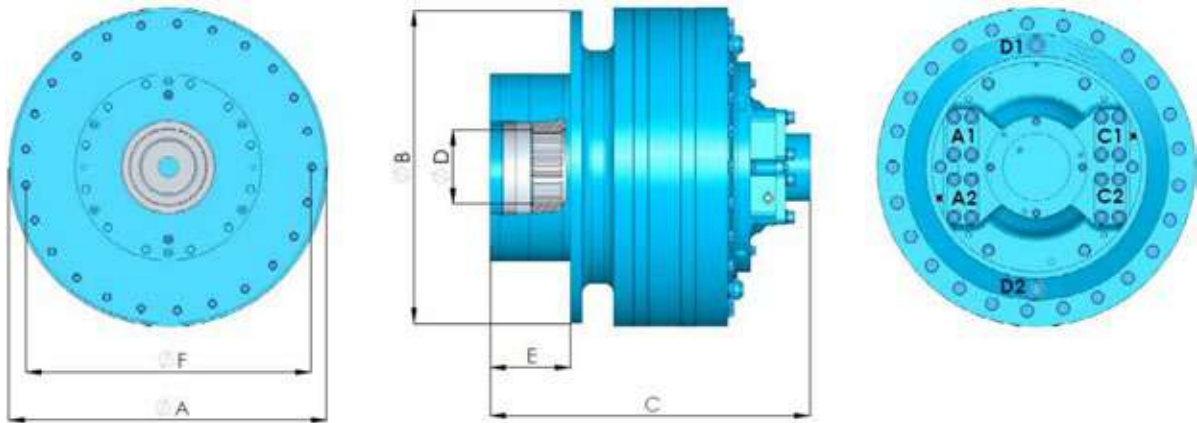

Motor	ØA (mm)	ØB (mm)	C (mm)	ØD (mm-DIN 5480)	E (mm)	ØF (mm) Mounting Dimensions for Torque Arm or Bracket	Weight Kg	Main conn A1, A2, C1, C2	Drain conn D1, D2
HMB 15*	820	803	916	N200x5x30x38x9H	256	25 Nos of Ø 22 THRU HOLES, PCD 740 ± 0.1	1650	SAE 2"	1-1/4" BSP

\* Technical dimensions are subject to change without prior notice

# 820 SERIES

## DIMENSIONS:

## TORQUE ARM AND BRAKE SPECIFICATIONS

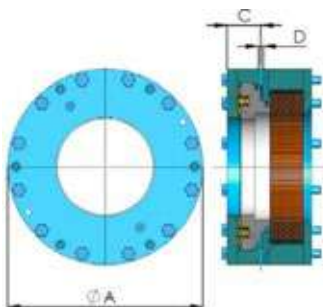

Motor	A (mm)	B (mm)	C (mm)	D (BSP)	BRAKE RELEASE PRESSURE	BRAKE TORQUE NM (MAX)
HMB 15-820	555	247	84	3/8"	50BAR	1,20,000

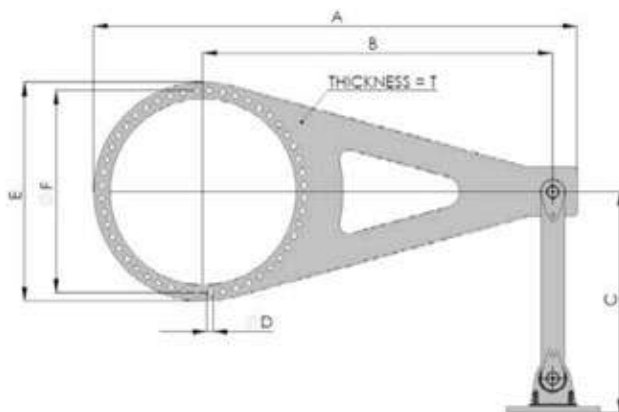

\* Technical dimensions are subject to change without prior notice

# CR SERIES

## ROTATING CASE

**SCHRODER CR Series** motors are designed for use in Marine, Steel and Mining industries for winches, cranes, haulage and constant tension equipment etc., where a continuous duty cycle with high efficiency and varying load conditions are demanded. They can be installed inside winch drums and form an integral part of the machine, enhancing the compactness of the entire system. The displacement varies from 4 lit/rev to 40 lit/rev. Our Rotating Case motors have a significantly enhanced and enlarged internal front bearing assembly to improve load bearing ability and with a greatly improved oil distribution system, can withstand greater bedframe misalignments, frequently experienced on ship mounted applications.

### OPTIONS

- INTEGRAL BAND BRAKE
- CORROSION RESISTANT MATERIAL
- CUSTOM FINISH
- NON MAGNETIC MATERIAL
- DUAL DISPLACEMENT

### FEATURES

- LONG LIFE
- HIGH MECHANICAL EFFICIENCY
- CONSTANT TORQUE OUTPUT
- SMOOTH LOW SPEED PERFORMANCE <1RPM
- RESISTANCE TO THERMAL SHOCK
- SHOCK RESISTANCE
- LOW NOISE



## CR – LD RANGE

MOTOR FRAME SIZE	SPECIFICATIONS				
	DISP.(*) PER REV	TORQUE (THEORETICAL)	SPEED RATED	SPEED MAX**	PRESSURE RATED
METRIC	cm <sup>3</sup> /Rev	Nm/Bar	RPM	RPM	Bar
LD-0380	3820	60	110	143	350
LD-0520	5205	82	110	143	350
LD-0730	7285	115	100	130	350
LD-0970	9735	150	90	117	350

\*\*High speed version upon request

\* Any other displacement upon request

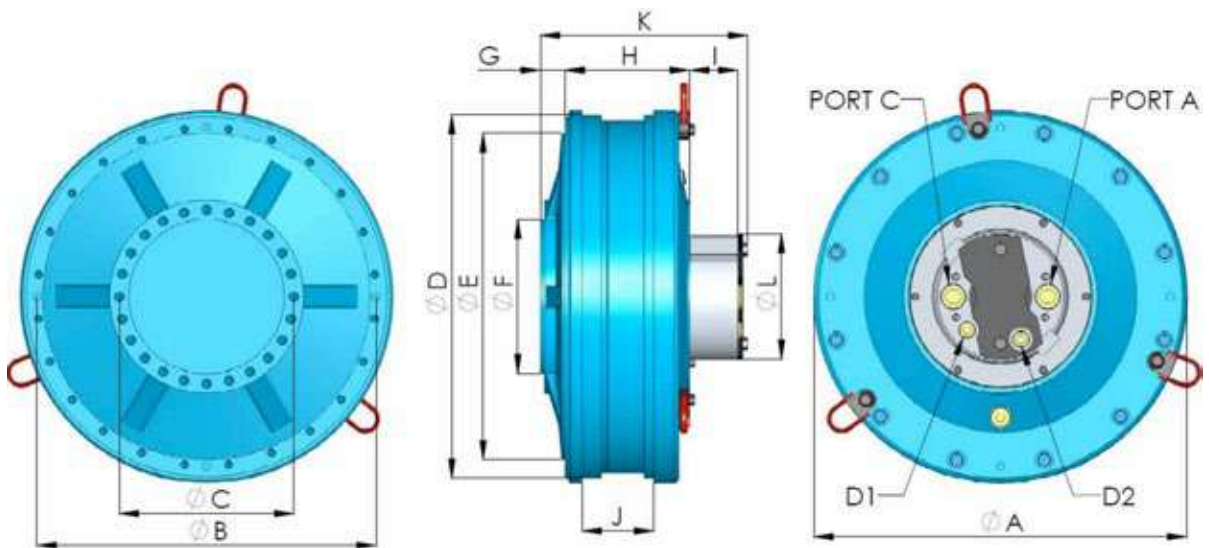

Motor	ØA (mm)	ØB (mm)	ØC (mm)	ØD (mm)	ØF (mm)	G (mm)	H (mm)	I (mm)	J (mm)	K (mm)	ØL (mm)	Wt. Kg	Main conn A, C	Drain conn D1, D2
CR-LD	770	24 Nos Eq. Spaced M16x35mm Deep at PCD of 700 ±0.1	24 Nos Eq. Spaced M16x35mm Deep at PCD of 700 ±0.1	752	320	51	264	100	149	408	260	600	1-1/ 4" BSP	3/4" BSP

\* Technical dimensions are subject to change without prior notice

### CR – MD RANGE

MOTOR FRAME SIZE	SPECIFICATIONS				
	DISP.(*) PER REV	TORQUE (THEORETICAL)	SPEED RATED	SPEED MAX**	PRESSURE RATED
METRIC	cm <sup>3</sup> /Rev	Nm/Bar	RPM	RPM	Bar
MD-0380	11575	184	80	104	350
MD-0520	13990	222	70	91	350
MD-0730	16800	275	60	78	350

\*\*High speed version upon request

\* Any other displacement upon request

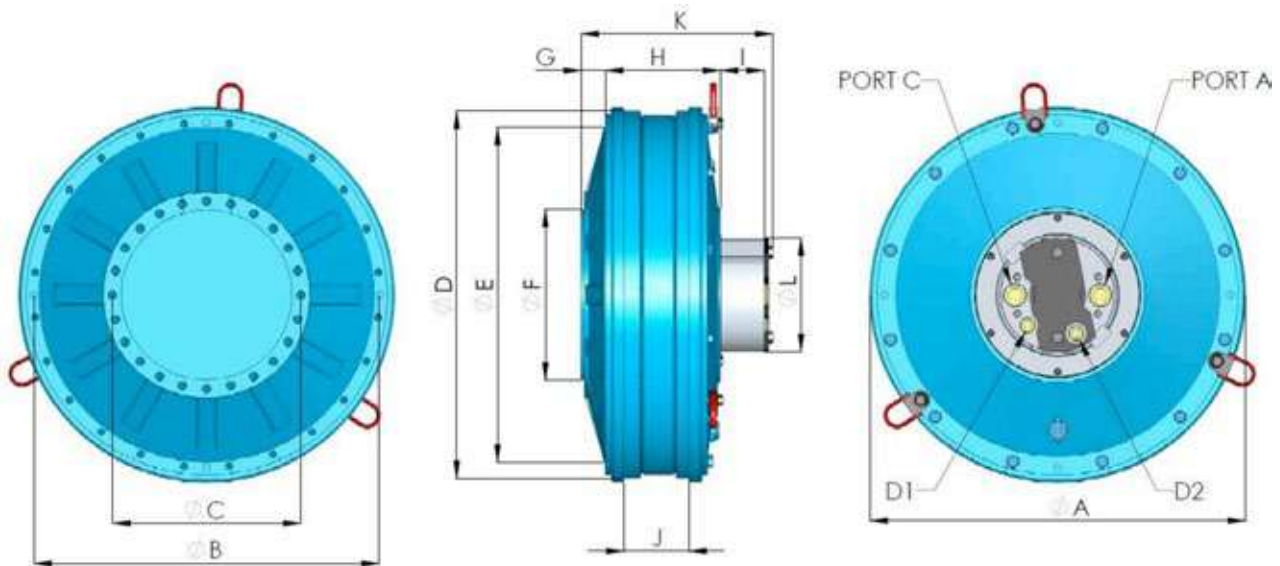

Motor	$\varnothing A$ (mm)	$\varnothing B$ (mm)	$\varnothing C$ (mm)	$\varnothing D$ (mm)	$\varnothing F$ (mm)	G (mm)	H (mm)	I (mm)	J (mm)	K (mm)	$\varnothing L$ (mm)	Wt. Kg	Main conn A, C	Drain conn D1, D2
CR-MD	858	24 Nos Eq. Spaced M16x35mm Deep at PCD of 790 $\pm 0.5$	24 Nos Eq. Spaced M16x35mm Deep at PCD of 430 $\pm 0.1$	550	180	190	700	832	832	832	832	2200	SAE 2"	1-1/4" SAE

\* Technical dimensions are subject to change without prior notice

## CR – HD RANGE

MOTOR FRAME SIZE	SPECIFICATIONS				
	DISP.(*) PER REV	TORQUE (THEORETICAL)	SPEED RATED	SPEED MAX**	PRESSURE RATED
METRIC	cm <sup>3</sup> /Rev	Nm/Bar	RPM	RPM	Bar
HD-15500	15335	242	65	85	350
HD-18400	18456	292	65	85	350
HD-21800	21870	348	65	85	350
HD-23000	22795	362	65	85	350
HD-25500	25585	407	65	85	350
HD-34000	34275	545	45	59	350
HD-38500	38945	612	50	65	350

\*\*High speed version upon request

\* Any other displacement upon request

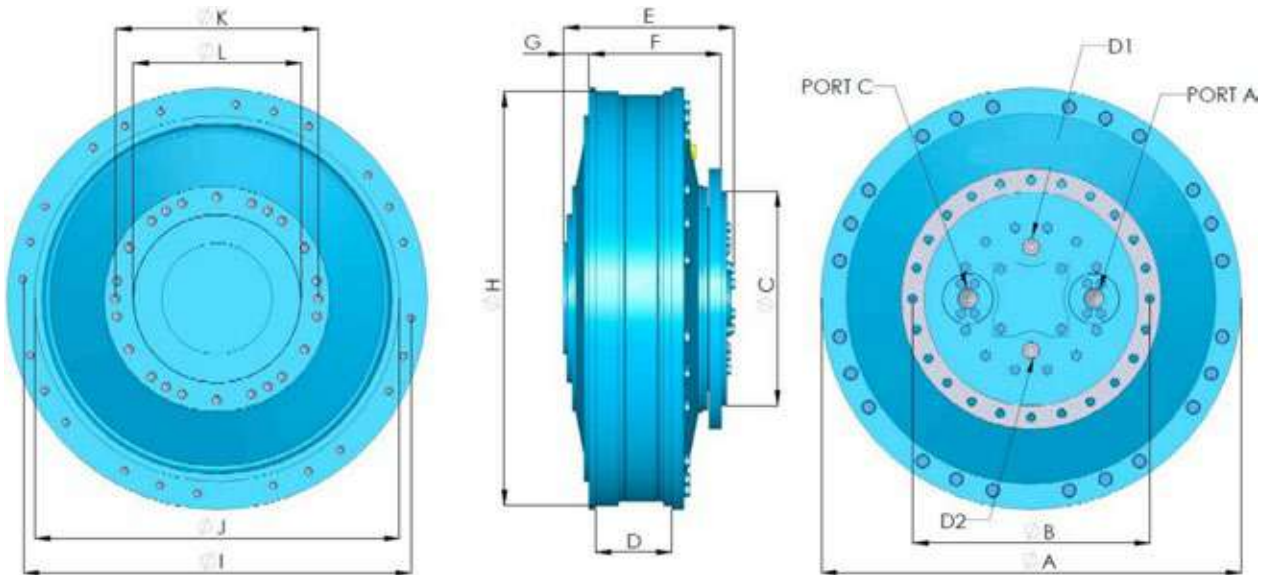

Motor	ØA (mm)	ØB (mm)	ØC (mm)	D (mm)	E (mm)	F (mm)	G (mm)	H (mm)	ØI (mm)	ØJ (mm)	ØK (mm)	ØL (mm)	Wt. Kg	Main conn (A, C)	Drain conn (D1, D2)
CR-HD	1100	24 Nos at PCD of 620 ±0.5	560	198.5	450	383	67	1080	24 Nos M20x46mm Deep at PCD of 1020 ±0.1	955	24 Nos M20x46mm Deep at PCD of 530 ±0.1	832	2200	SAE 2"	1-1/4" SAE

\* Technical dimensions are subject to change without prior notice

## TORQUE ARM AND BRAKE SPECIFICATIONS

### INTEGRAL BRAKE SYSTEMS (Static / Parking)

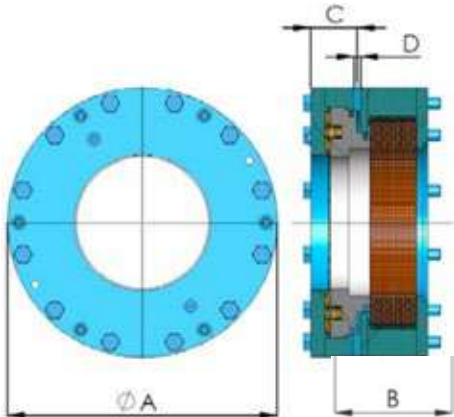

Motor	A (mm)	B (mm)	C (mm)	D (mm)	BRAKE RELEASE PRESSURE	BRAKE TORQUE (MAX) NM
HM 3.2 – 5	400	165	53	1/4"	20 – 30 BAR	16,600
HM 5 – 6	400	165	53	1/4"	20 – 30 BAR	25,000
HM 7.5 – 9	400	165	53	1/4"	20 – 30 BAR	32,000
HM 10 – 12	480	195	62	3/8"	20 – 30 BAR	60,000
HM 15	480	195	62	3/8"	20 – 30 BAR	80,000
HM 25 – 36	480	211	86	3/8"	50 BAR	80,000
HM 10 – 15 (820 Series)	555	247	84	3/8"	50 BAR	80,000
HM 17.5 – 20 (820 Series)	555	247	84	3/8"	50 BAR	100,000
HM 15 (820 Series)*	480	211	86	3/8"	50 BAR	120,000

\* This brake is specially designed for Wagon Tippler (Rail Car Dumper) applications

### TORQUE ARM SPECIFICATIONS

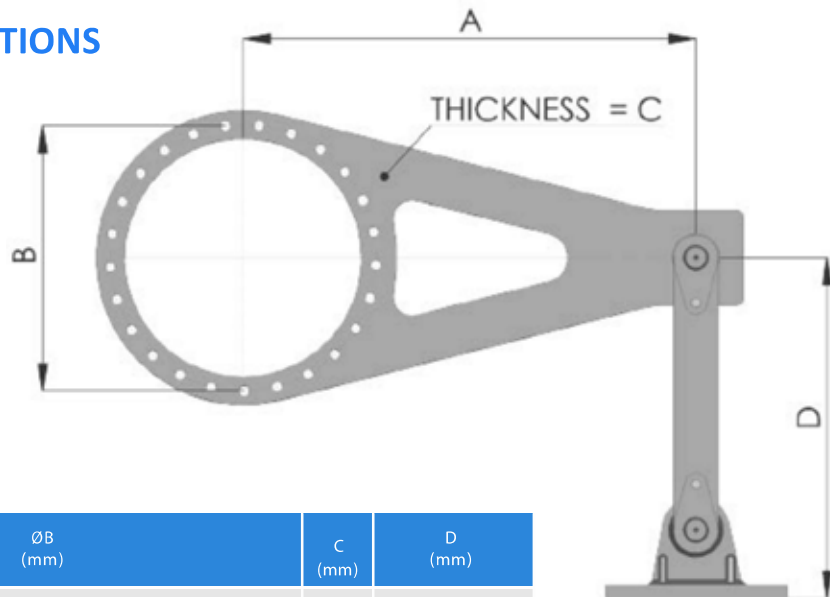

Motor Type	A (mm)	∅B (mm)	C (mm)	D (mm)
LD SERIES	1000	8 SETS OF 2 HOLES ∅22 EQUALLY SPACED ON PCD 587 ± 0.2	30	TO SUIT CUSTOMER REQUIREMENTS
MD SERIES	1000	∅22 X 25 HOLES EQUALLY SPACED ON PCD 587 ± 0.2	30	
HD SERIES	1500	∅22 X 25 HOLES EQUALLY SPACED ON PCD 587 ± 0.2	40	
HM SERIES	2500	∅22 X 25 HOLES EQUALLY SPACED ON PCD 587 ± 0.2	50	
820 SERIES	1500	∅22 X 25 HOLES EQUALLY SPACED ON PCD 587 ± 0.2	40	

## CROSS-PORT RELIEF VALVES

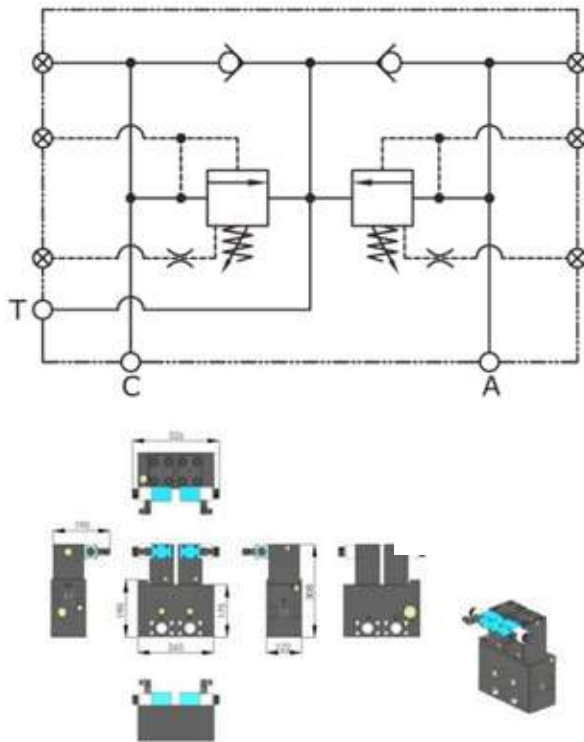

Motor (LITRES)	Pressure Ratings (BAR)	Flow (LPM)
HM 3.2	350	352LPM
HM 3.9	350	430LPM
HM 5.0	350	700LPM
HM 6.0	350	720LPM
HM 6.5	350	650LPM
HM 7.5	350	750LPM
HM 9.0	350	720LPM
HM 12.0	350	900LPM
HM 13.5	350	1013LPM
HM 15.0	350	1050LPM
HM 20.0	350	900LPM
HM 25.0	350	1000LPM
HM 30.0	350	1050LPM
HM 36.0	350	1152LPM
HM 50.0	350	1300LPM

## SPEED SENSORS

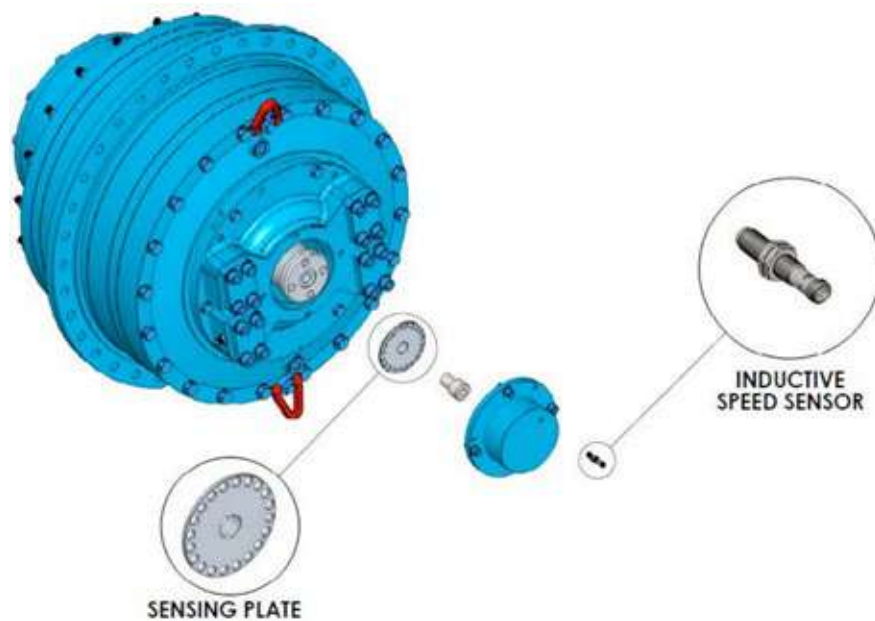

## MODEL DESIGNATION CODES

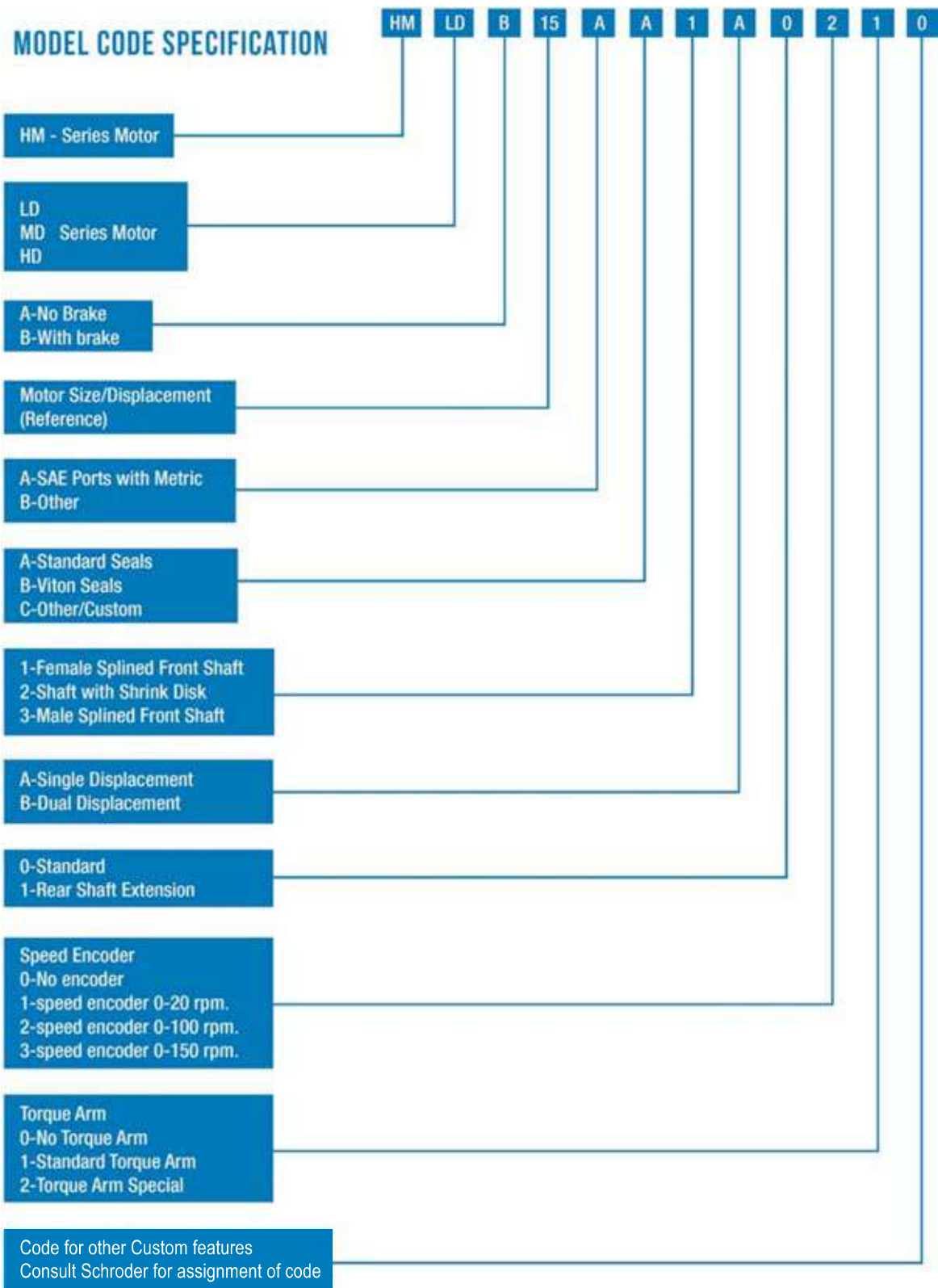

## MODEL DESIGNATION CODES

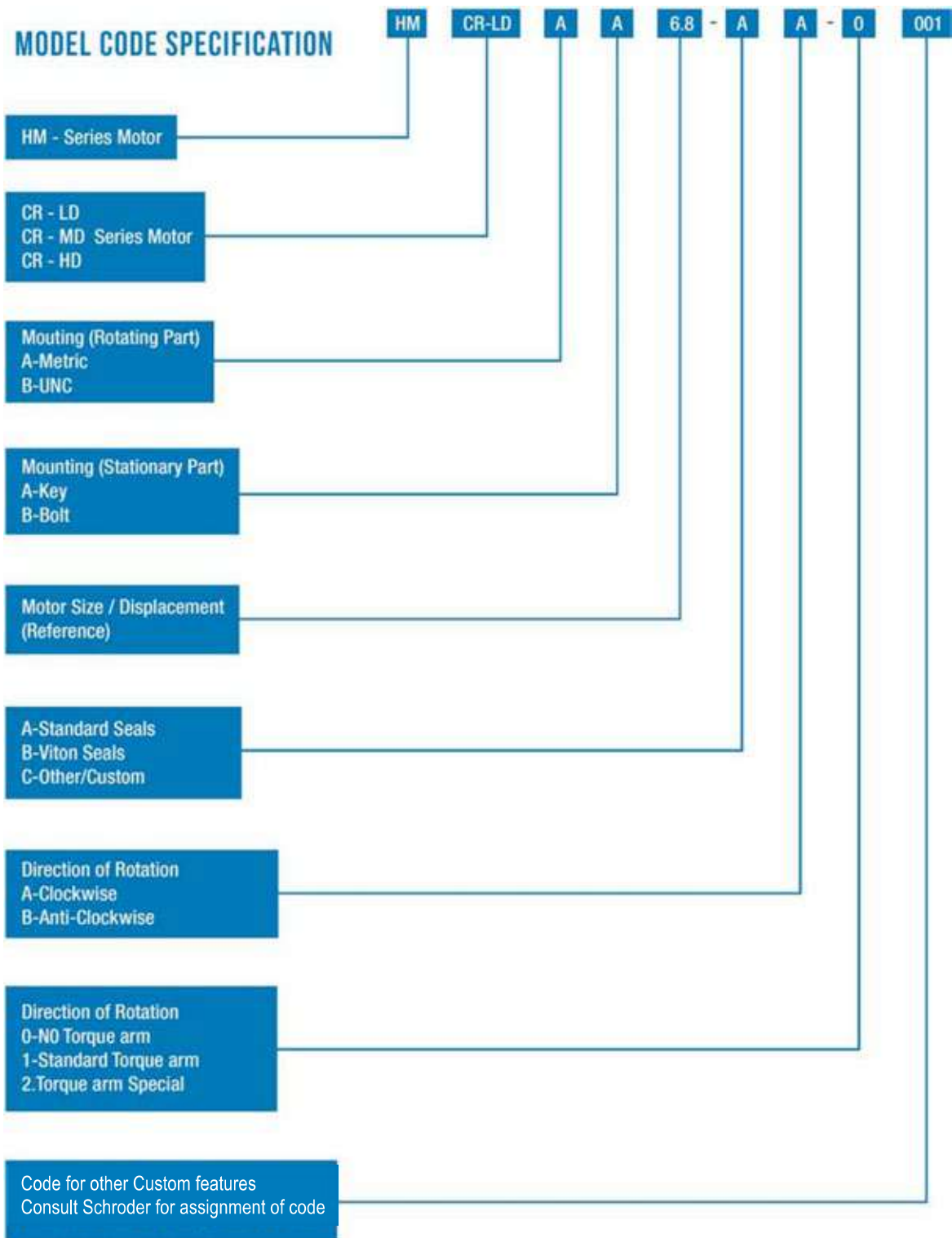

# Installation Examples & Retro-Fits

**SCHRODER HYDRAULICS** are able to supply complete drive-systems and components of the highest quality based upon our unique hydraulic piston motors. We can provide a perfectly matched drive system to suit all needs, including piping, installation and commissioning. Our products are designed to give direct drive to many applications, eliminating the need of gearboxes and fluid couplings. You achieve benefits of simplicity, saving space, improved control, reduced costs and gain high reliability with low maintenance in almost any environment.



Twin Roll Wash Press Drive for Pulp & Paper Industry



2000 TPH Bucket Wheel Reclaimer Drive Conversion



4000 TPH Bucket Wheel Reclaimer Drive



2000 TPH Conveyor Drive Conversion

**SCHRODER HYDRAULICS** can undertake the design and manufacture of custom-built hydraulic equipment as per the customer's requirements and offer consultancy services for upgrading and modification of existing hydraulic systems. In Recent years the application of Hydraulic drives for Bulk Material Handling Equipment has been increasing at a rapid phase compared to Electro-mechanical drives. Many customers whose machines were previously electric motor/gear box drive, are now converting their machines Hydrostatic drive for higher productivity, reliability and ease of maintenance.

# Integrated Drive System Power Packs

Hydraulic motors are driven by the use of a Power Pack. The power packs come in a wide range of designs and sizes, with single, double, triple and even quad drive pump assemblies to suit the speed and duty demands of the various applications. Power Packs can be just a simple basic design with minimal functions for low budget applications, or can be equipped with state of the art technology, including inbuilt PLC and modem facilities for on-line monitoring and control, and even remote adjustments. Whatever the level of technicalities, all power packs consist of a tank unit along with hydraulic pump and electric motor to drive the pump. All power packs have basic self-protection and monitoring equipment.



**Tandem Drive – Vertically Mounted Pump-Motors  
Front & Rear Views of Sound-Proof Cabinets**



**Mini Power Unit**



**Horizontal Mounted Power Pack**



**Multiple Twin Drive Conveyor Power Packs**

# Dedicated Control Systems

## Intelligent Drives



The **SCHRODER HYDRAULICS** HPU drives the hydraulic motor and controls the speed and safety of the entire drive system from a local control system.

The Control System is an integrated part of the HPU and uses a dedicated PLC system with **SCHRODER HYDRAULICS** purpose designed programs for all the different pump and motor types and functions, depending upon the individual application requirements.



The Power Unit can be operated directly from the Control Unit LCD panel, but it is also possible to control the drive remotely from additional external control systems, provided by the customer. The Power Unit is a very flexible product with a wide option range. This makes it possible to select a standard Power Unit to fulfill the specialized requirements needed in many different Applications.



The HPU is equipped with a range of monitoring devices, designed to protect the HPU main components. These monitoring devices are connected to the control system PLC, so that the system can automatically make adjustments to command settings, give warnings and alarms to the operators both locally and to central control rooms and ultimately shut down the system should the problem being encountered continue without attention.

All of these features makes the **SCHRODER HYDRAULICS** drive system truly intelligent.

# Other Applications



## Rubber & Plastics

- ❖ Mixing Machines
- ❖ Process Machines
- ❖ Belt Process
- ❖ Screw Drives



## Mining

- ❖ Conveyors
- ❖ Reclaimers
- ❖ Stackers
- ❖ Apron Feeders
- ❖ Unloaders
- ❖ Crushers



## Pulp & Paper Industry

- ❖ Waste Paper Handling
- ❖ Digester mixers
- ❖ Washing and Bleaching
- ❖ Chip Feeders



## Marine

- ❖ Winch Drives
- ❖ Steering
- ❖ Dredgers
- ❖ Crawlers
- ❖ Drive Barges



## Sugar

- ❖ Mill Drives
- ❖ Pressure Feeders
- ❖ Cane Carriers
- ❖ Cane Unloaders



## Power

- ❖ Ball Mills
- ❖ Bowl Mills
- ❖ Feeder Conveyors
- ❖ Ash Handling
- ❖ Feeding Gates
- ❖ Conveyors



## Material Handling

- ❖ Conveyors
- ❖ Wagon Tipplers
- ❖ Side Arm Charges
- ❖ Paddle Feeders
- ❖ Apron Feeders
- ❖ Stacker Reclaimers



## Cement

- ❖ Kiln Drivers
- ❖ Driers
- ❖ Chemical
- ❖ Evaporators
- ❖ Mixers
- ❖ Reactors

# Advantages

Hydraulic drive systems provide advantages that no electro-mechanical drive can match. Installing hydraulic drives on your equipment will give you:

- ❖ **Maximum Torque from Zero Speed**
- ❖ **High Performance in all Conditions**
- ❖ **Precise Control in Forward and Reverse Directions**
- ❖ **Compact Size with Increased Power**
- ❖ **Low Maintenance**
- ❖ **Increased Reliability**

Hydraulic drive systems offer the smart drive solution whatever your drive requirement.

## HEAVY DUTY RADIAL PISTON HYDRAULIC MOTORS



HIGH TORQUE RADIAL PISTON MOTORS  
HYDRAULIC PUMPS & CYLINDERS  
POWER PACKS & ACCESSORIES  
COMPLETE DRIVE SYSTEMS



# Reliable Gearless Hydraulic Drives

For High Torque Applications



HEAVY DUTY RADIAL PISTON MOTORS AND COMPLETE DRIVE SYSTEMS



---

A large version of the Schroder logo is centered on the page. It consists of the same stylized circular emblem on the left, followed by the word "SCHRODER" in bold black text inside a light blue pill-shaped background. Below this, the word "HYDRAULICS" is written in a large, bold, black, sans-serif font.

HEAVY DUTY RADIAL PISTON MOTORS AND COMPLETE DRIVE SYSTEMS